

Model No. LT-103S

Base Plate Two Post Lift,

Manual Release

**Installation, Operation
and Parts Manual**

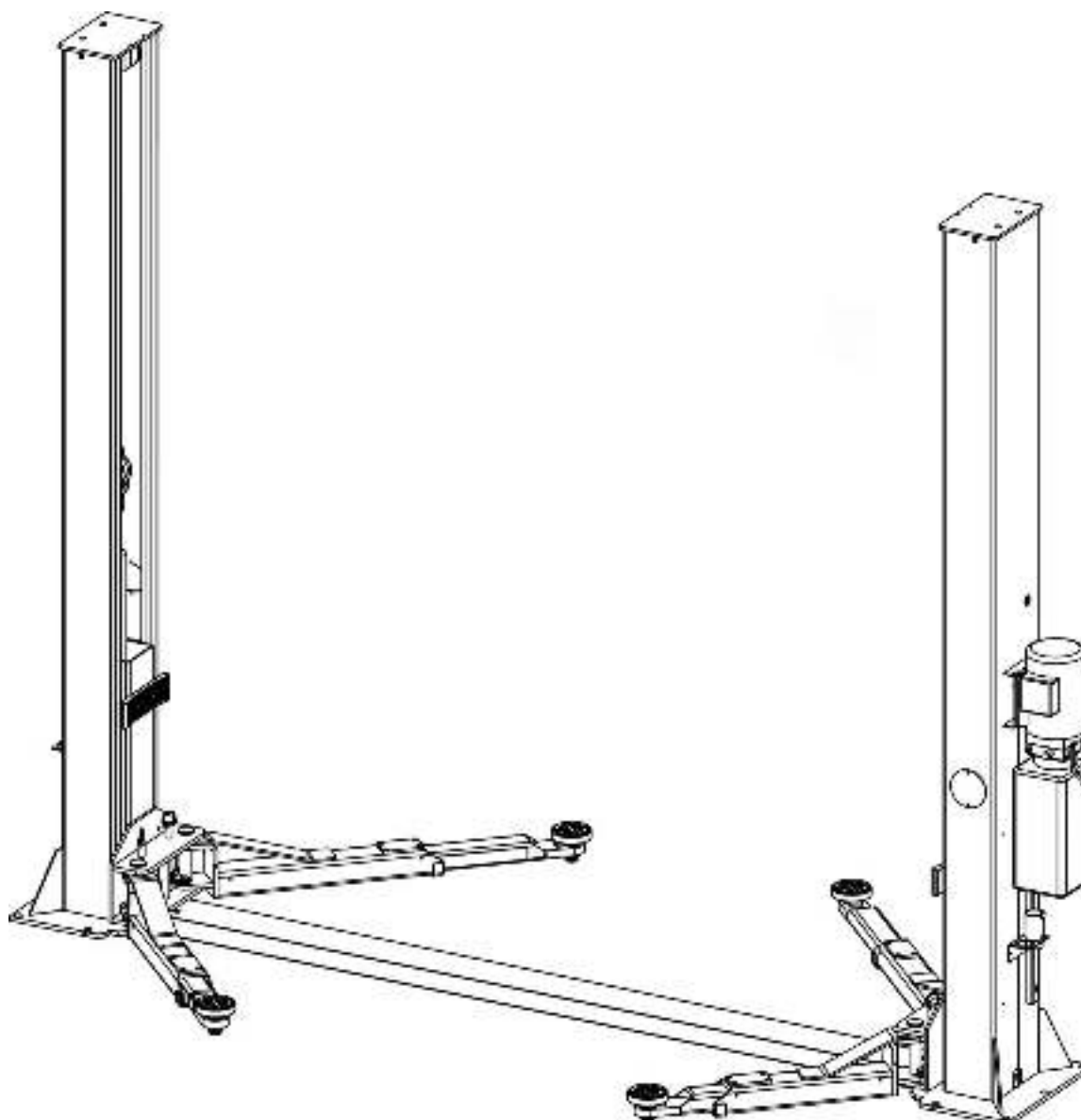

Read this entire manual carefully and completely before installation or operation of the lift.

INDEX

1. Important safety instructions.....	3~4
1.1 Important notices	
1.2 Qualified personnel	
1.3 Danger notices	
1.4 Training	
1.5 Warning signs	
2. Overview of the lift.....	5
2.1 General descriptions	
2.2 Technical data	
2.3 Construction of the lift	
3. Installation instructions.....	6~12
3.1 Preparations before installation	
3.2 Precautions for installation	
3.3 Installation	
3.4 Items to be checked after installation	
4. Operation instructions.....	13~14
4.1 Precautions	
4.2 Flow chart for operation	
4.3 Operation instructions	
5. Trouble shooting.....	15
6. Maintenance.....	16
7. Annex.....	17~30
Annex1, Packing list of the whole lift	
Annex2, Overall diagram	
Annex3, Floor plan	
Annex4, Hydraulic working system	
Annex5, Wiring diagram	
Annex6, Separated drawings for the lift	
Annex7, Spare parts list	

IMPORTANT SAFETY INSTRUCTIONS

1.1 Important notices

We will offer one-year's quality warranty for the whole machine, during which any quality problem will be properly solved to the user's satisfaction. However, we will not take any responsibility for whatever bad consequence resulted from improper installation and operation, overload running or unqualified ground condition.

This 2-posts lift is specially designed for lifting motor vehicles that weighs within its outmost lifting capacity. Users are not allowed to use it for any other purposes. Otherwise, we, as well as our sales agency, will not bear any responsibility for accidents or damages of the lift. Make sure to pay careful attention to the label of the lifting capacity attached on the lift and never try to lift cars with its weight beyond.

Read this manual carefully before operating the machine so as to avoid economic loss or personnel casualty incurred by wrong operation. Without professional advice, users are not permitted to make any modification to the control unit or whatever mechanical unit.

1.2 Qualified personnel

1.2.1 Only these qualified staff, who have been properly trained, can operate the lift.

1.2.2 Electrical connection must be done by a competent electrician.

1.2.3 People who are not concerned are not allowed in the lifting area.

1.3 Danger notices

1.3.1 Do not install the lift on any asphalt surface.

1.3.2 Read and understand all safety warnings before operating the lift.

1.3.3 The lift, if is not specially designed upon customer's request, is not fit for outdoor use.

1.3.4 Keep hands and feet away from any moving parts. Keep feet clear of the lift when lowering.

1.3.5 Only these qualified people, who have been properly trained, can operate the lift.

1.3.6 Do not wear unfit clothes such as large clothes with flounces, tires, etc, which could be caught by moving parts of the lift.

1.3.7 To prevent evitable incidents, surrounding areas of the lift must be tidy and with nothing unconcerned.

1.3.8 The lift is simply designed to lift the entire body of vehicles, with its maximum weight within the lifting capacity.

1.3.9 Always insure the safety latches are engaged before any attempt to work near or under the vehicle.

1.3.10 Make sure to place the lifting pads to the positions as suggested by vehicle makers and when gradually lift the vehicle to the desired height, operators should be certain that the vehicle will not slant, roll-over or slide in lifting process.

1.3.11 Check at any time the parts the lift to ensure the agility of moving parts and the performance of synchronization. Ensure regular maintenance and if anything abnormal occurs, stop using the lift immediately and contact our dealers for help.

1.3.12 Lower the lift to its lowest position and do remember to cut off the power source when service finishes.

1.3.13 Do not modify any parts of the lift without manufacturer's advice.

1.3.14 If the lift is going to left used for a long time, users are required to:

- a. Disconnect the power source;
- b. Empty the oil tank;
- c. Lubricate the moving parts with hydraulic oil.

1.4 Training

Only these qualified people, who have been properly trained, can operate the lift. We are quite willing to provide professional

training for the users when necessary.

Attention: For environment protection, please dispose the disused oil in a proper way.

1.5 Warning signs

All safety warning signs attached on the machine are for the purpose of drawing the user's attention to safety operation. The labels must be kept clean and need to be replaced when they are worn-out or have dropped. Read the explanations of the labels carefully and try to memorize them.

CAUTION
 Remain clear of lift when lowering or lifting vehicle.

CAUTION
 Clear area if vehicle is in danger of falling.

CAUTION
 Lift vehicle at the manufacturer's points

CAUTION
 Always use safety stands when removing/ installing heavy components

CAUTION
 Locate the vehicle with center gravity right between two adapters.

CAUTION
 Keep feet away from adapter while lift lowering.

CAUTION
 Use height extension when necessary to ensure good contact.

CAUTION
 Auxiliary adapters may reduce load capacity.

WARNING
 Do not override self-closing lift controls

WARNING
 Do not shake vehicle heavily while on lift.

WARNING
 Read the manual before installation or operation of the lift.

WARNING
 1. Traveling on the load-carrying devices is forbidden.
 2. After raising a short distance, checked to ensure that it is correctly and safely positioned.
 3. It is forbidden to climb onto the load or load-carrying devices when they are raised.

CAUTION
 Lift is only allowed to be used by trained operator.

CAUTION
 Only authorized personnel allowed in lift area

CAUTION
 Arms must support the rated load weight as the following diagram.

Lift capacity	Load distribution	
	A	B
2.5T	1.125T	1.375T
3.5T	1.125T	2.375T
4.5T	1.125T	3.375T
5.5T	1.125T	4.375T

Lift capacity	Load distribution	
	A	B
2.5T	1.125T	1.375T
3.5T	2.125T	1.375T
4.5T	2.625T	1.875T
5.5T	3.125T	2.375T

OVERVIEW OF THE LIFT

2.1 General descriptions

This floor plate two posts lift is composed of posts, carriages, lifting arms, cylinders and motor unit, etc.

It is driven by an electro-hydraulic system. The gear pump delivers hydraulic oil to oil cylinders and pushes upwards its piston. The

piston drives the chain to raise the carriage and the lifting arms. During lifting process, the safety latch will automatically and firmly bite with the safety teeth block in the posts. Therefore, no slipping will happen in case the hydraulic system beaks down.

Safety structure



2.2 Technical data

Model	Lifting capacity	Full rise time	Full rise	Height	Width	Inside columns
LT-103S	4200kg	50 Sec	1920mm	2824mm	3436mm	2850mm

2.3 Construction of the lift

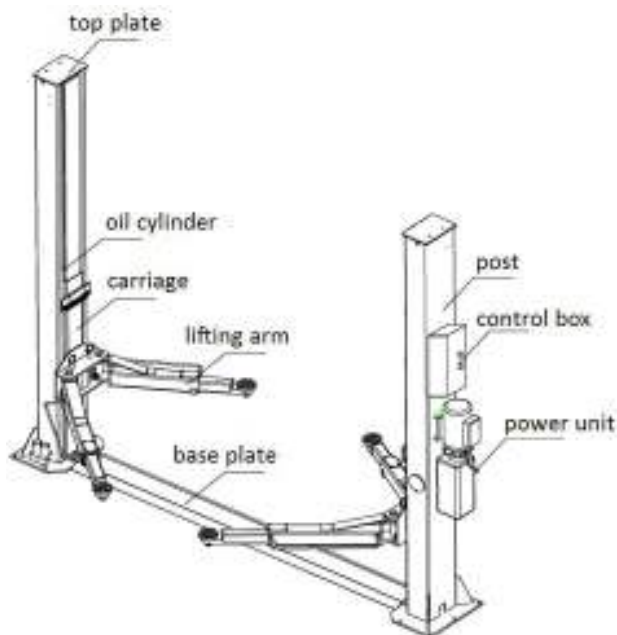

INSTALLATION INSCRUCTIONS

3.1 Preparations before installation

3.1.1 Tools and equipments needed

- ✓ Appropriate lifting equipment
- ✓ Anti-abrasion hydraulic oil.
- ✓ Rotary Hammer Drill with 3/4" drill bit.
- ✓ Chalk and tape measure, magnetic plump, 8 metersΦ15 level pipe.

-
- ✓ Sockets and open wrenches, a set of inside hex wrenches, cross and straight screw drivers.
 - ✓ Hammer, 4pounds, sharp nose pliers, $\Phi 17, \Phi 19, \Phi 22$ socket spanners.

3.1.2 List for parts checking ---Annex 1 (Packing list)

Unfold the package and check if any parts missed as per Annex 1. Do not hesitate to contact us in case any parts missed, but if you do not contact us and insist installing upon the lack of some parts, EOUNICE as well as our dealers will not bear any responsibility for this and will charge for any parts subsequently demanded by the buyer.

3.1.3 Ground conditions

The lift should be fixed on a smooth and solid concrete ground with its strength more than 3000psi, tolerance of flatness less than 5mm and minimum thickness of 200mm. In addition, newly built concrete ground must undergo more than 28days' cure and reinforcement.

3.2 Precautions for installation

- 3.2.1 Make sure the two posts stand paralleled and are vertical to the ground. No slanting.
- 3.2.2 Joints of oil hose and steel cable must be firmly connected in order to avoid the looseness of steel cable and leakage of oil hose.
- 3.2.3 All bolts should be firmly screwed up.
- 3.2.4 Do not place any vehicle on the lift in the case of trial running.

3.3 Installation

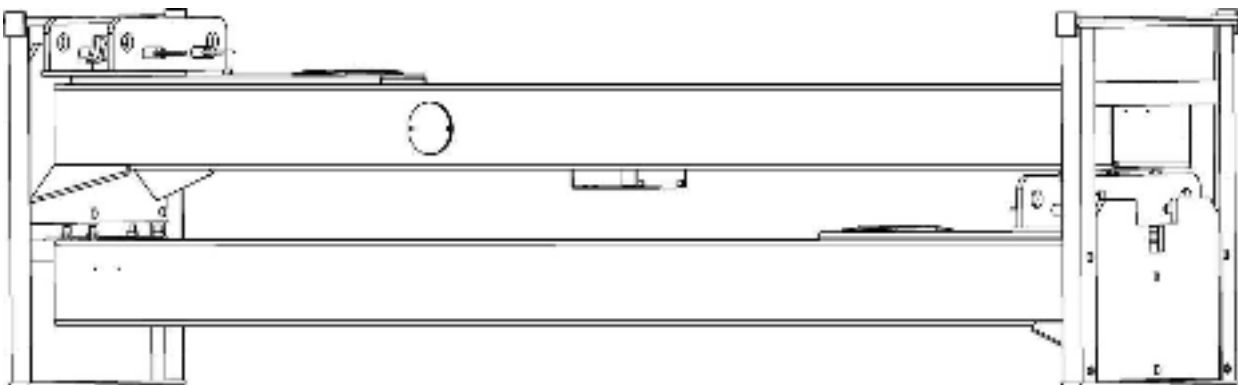

Step 1: Remove the packaging, take out the carton for accessories and cover plate.

Step 2: Firstly, put something supporting between the two posts or suspend one of the posts by a crane and then remove the bolts on the package.

Attention: Please pay special attention not to let the post fall down for it may cause casualty or bring damages to the accessories fixed in the post.

Step3: When the first post has been taken away, place something supporter under the second post and then remove the bolts on the package.

Step 4: Fix the standing position for the two posts. (See Annex 3, floor plan)

1. Unfold the package and decide on which post the power unit will be mounted.
2. Draw an outline of the base plate on the ground with chalk and ascertain the position for the post.

Step 5: Erect the posts, power side post first and then the other post.

1. Drill anchor holes for expansion bolts on the ground with an electrical drill. Make sure to drill vertically.
2. After holes have been drilled, remove thoroughly the debris and dust in them and ascertain that the posts stay upon the circle

previously drawn by chalk.

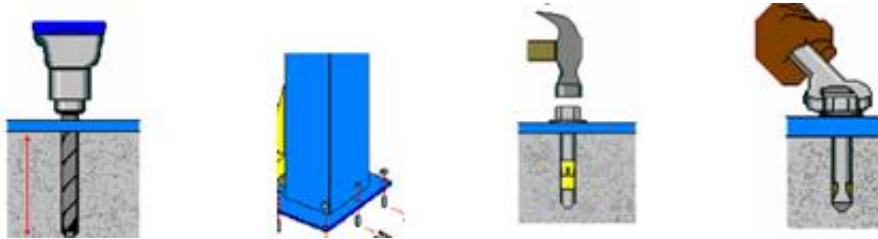

Step 6: Fix the slot base plate.

Manually raise two carriages about 800mm from the ground to have them locked by safety locks and then place the slot base plate between two base plates of the post.

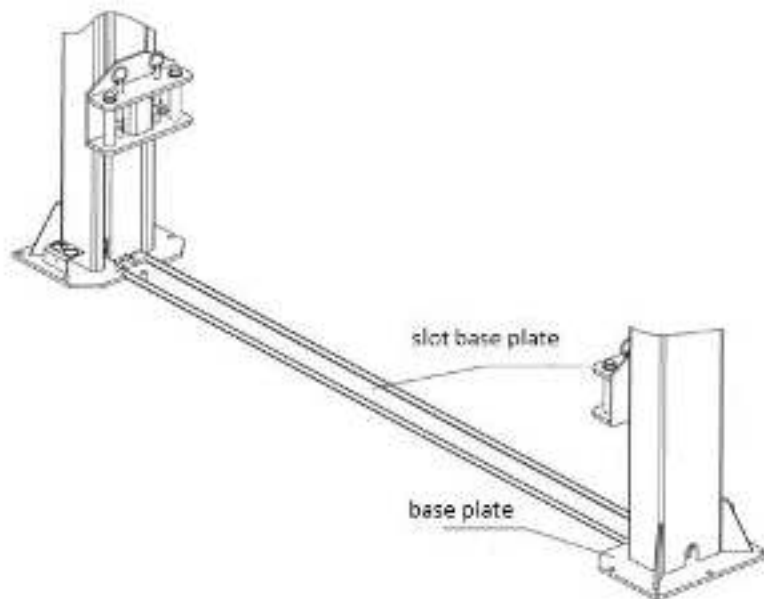

Step7: Connect steel cables.

1. Route and fix according to the following diagram of steel cable connection.
2. Raise carriages on both sides approximately 800mm above the ground. Carriages must be on the same height from the floor.
3. Make sure that the mechanical safety locks in each post are fully engaged before attempting to route cables.
4. After the cable being fixed, adjust and make the cable at both sides be with the same tightness which could be judged by the sound emitted during lifting process. Make judge and adjustment after trial running.
5. Grease after being fixed. (It is a must.)

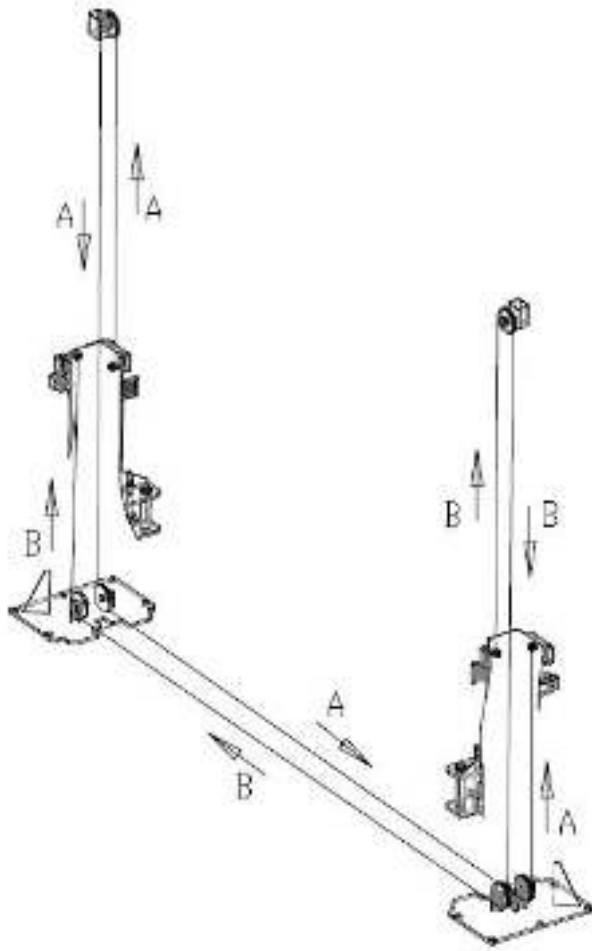

Step8: Mount the power unit onto the power side post.

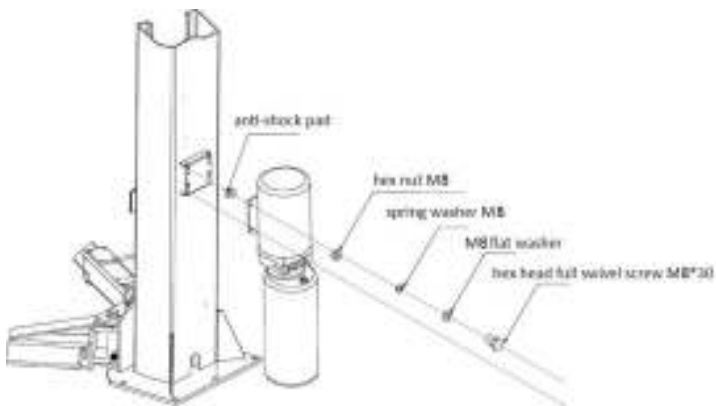

Step9: Connect oil hoses.

Connect the oil hose as per the following diagram.

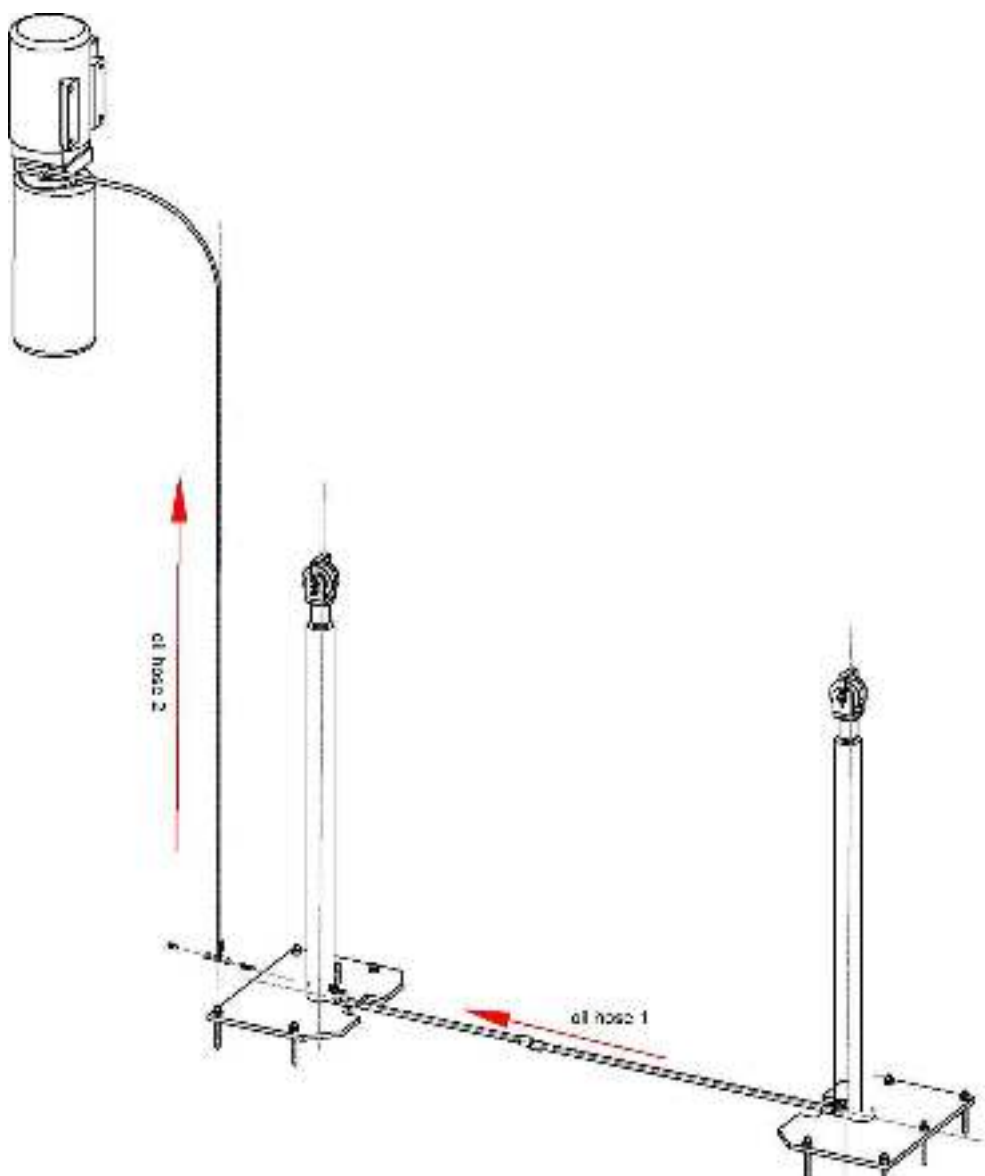

Step10: Connect wires.

1. Mount the control box on to the power side post.

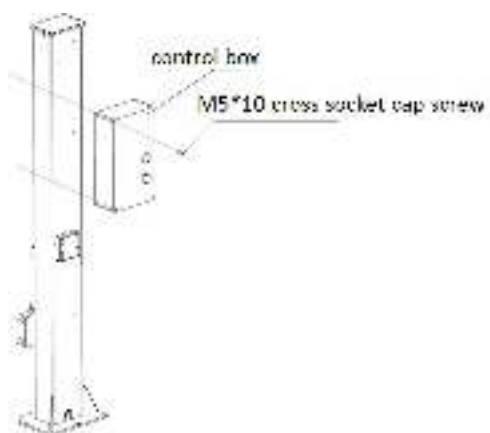

2. Fix the limit switch into the power side post.

Step11: Install lifting arms.

Connect the lifting arm and the carriage by shafts.

Install the lifting arms onto the carriages and ensure the arm lock could work.

Step12: Fill with hydraulic oil.

The volume of oil tank is 10L.To insure the lift work normally, the amount of oil in it should at least reach 80% of the tank's total volume. 32#anti-abrasion hydraulic oil for winter, 46# for summer.

Step13: Trial running.

1. Do refer to the operation instructions in advance and keep in mind that no vehicle left on the lift in the process of trial running.
2. Check if mechanical locks can be well engaged or released in the running process. Adjust by screwing the hex head screw as showed in the following drawing in case the locks do not work well. (Screw clockwise in case the lock can not release and screw counterclockwise in case the lock can't be engaged.)
3. Check and ensure all the connections are in good condition.
4. No vehicle on the lift during trial running.

Step14: Fix feet protection fenders, chain protection clothes, door-opening protections and lifting trays. Fix base cover plate.

3.4 Items to be checked after installation.

S/N	Check items	YES	NO
1	Are the posts vertical to the floor?		
2	Are the two posts paralleled?		
3	Is the oil hose well connected?		
4	Is the steel cable well connected?		
5	Are all lifting arms well fixed?		
6	Are electrical connections right?		
7	Are the rest joints firmly screwed?		
8	Are all items need lubricating added with grease?		

OPERATION INSTRUCTIONS

4.1 Precautions

4.1.1 Check all the joints of oil hose. Only when there is no leakage, the lift can start work.

4.1.2 The lift, if its safety device malfunctions, shall not be used.

4.1.3 The machine shall not lift or lower an automobile if its center of gravity is not positioned midway of the swing arms. Otherwise, the EOUNICE as well as our dealers will not bear any responsibility for any consequence resulted thereby.

4.1.4 Operators and other personnel concerned should stand in a safety area during lifting and lowering process.

4.1.5 When lifting arms rise to the desired height, switch off the power at once to prevent any mal-operation done by unconcerned people.

4.1.6. Make sure the safety lock of the lift is engaged before start working under the vehicle and no people under the vehicle during lifting and lowering process.

4.2 Flow chart for operation

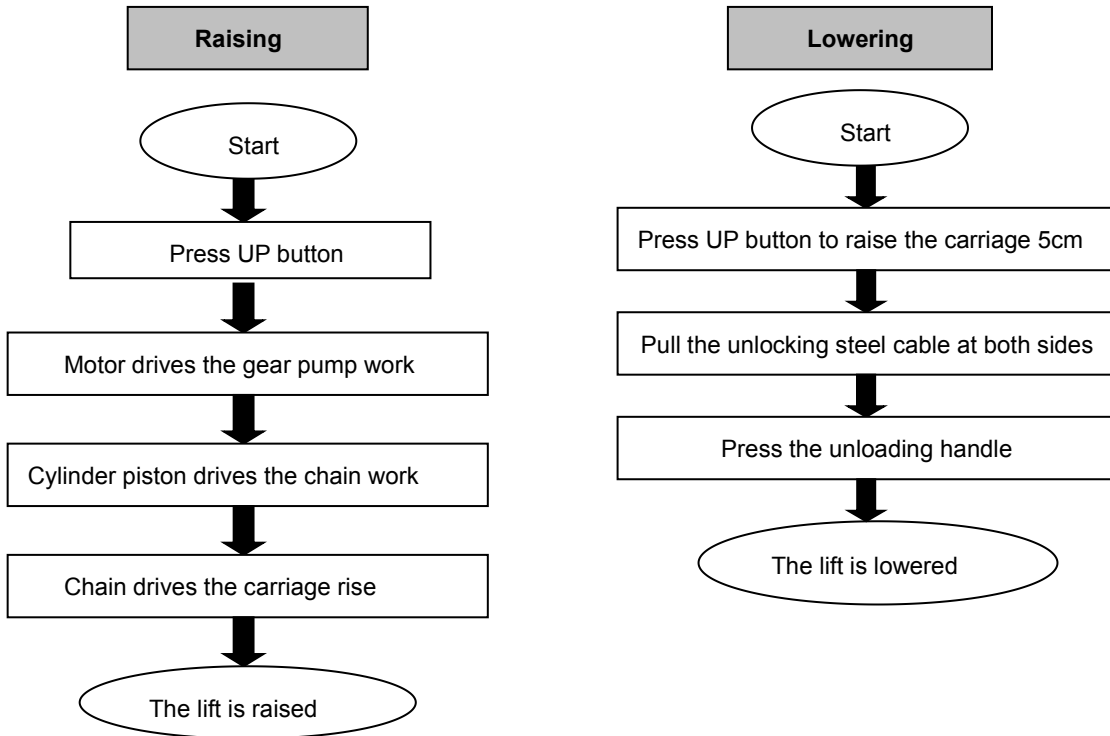

4.3 Operation instructions

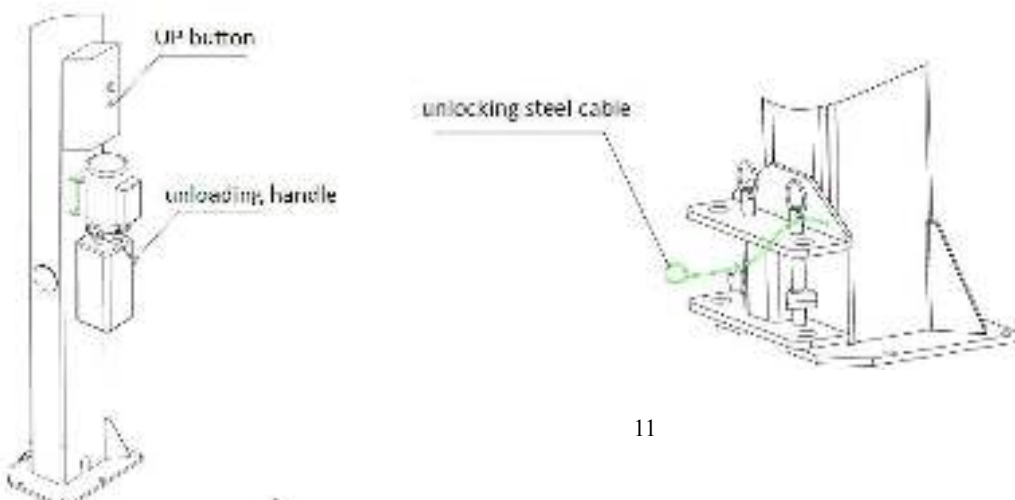

Raise the lift

1. Make sure that you have read and understood the operation manual before operation.
2. Park the vehicle between two posts.
3. Adjust the lifting arms until they reach the supporting positions of the vehicle and make sure the gravity of vehicle located in the center of four lifting arms.
4. Connect the power supply as per requirements on the nameplate attached, and switch on.
5. Press the "UP" button on the control box until pads of lifting arms touched the prop-position of vehicle.
6. Keep on raising the vehicle to let it have a bit clearance from the ground and check again its stability.
7. Raise the vehicle to the desired height, check it is safe or not, press the "unlocking handle" button to have the safety locks engaged, and then perform maintenance or repair work underneath.

Lower the lift

1. Press the "UP" button on the control box to raise the lifting arms about 5CM which loses the safety lock.
2. Pull the unlocking steel cable at both sides to release the safety locks.
3. Press the unloading handle to lower the arms.
4. After the lifting arms lower to the lowest position, pull them out from under the vehicle and clear up all the obstacles.
5. Drive the vehicle away.

TROUBLE SHOOTING

ATTENTION: If the trouble could not be fixed by yourself, please do not hesitate to contact us for help .We will offer our service at the earliest time we can. By the way, troubles could be judged and solved much faster if more details or pictures could be provided.

TROUBLES	CAUSE	SOLUTION
Abnormal noise	Abrasion exists on insider surface of the posts.	Grease the inside of the post.
	Trash in the post.	Clear the trash
Motor does not run and will not rise	The wire connection is loose.	Check and make a good connection.
	The motor is blown.	Replace it.
	The limit switch is damaged or the wire connection is loose.	Connect it or adjust or replace the limit switch.
Motor runs but will not raise	The motor run reversely.	Check the wire connection.
	Overflow valve is loose or jammed.	Clean or adjust it.

	The gear pump is damaged.	Replace it.
	Oil level is too low.	Add oil.
	The oil hose became loose or dropped off.	Tighten it.
	The cushion valve became loose or jammed.	Clean or adjusts it.
Carriages go down slowly after being raised	The oil hose leaks.	Check or replace it.
	The oil cylinder is not tightened.	Replace the seal.
	The single valve leaks.	Clean or replace it.
	Solenoid valve fails to work well.	Clean or replace it.
	Steel cable is loose or not with same tightness.	Check and adjust the tightness.
Raising too slow	The oil filter is jammed.	Clean or replace it.
	Oil level is too low.	Add oil.
	The overflow valve is not adjusted to the right position.	Adjust it.
	The hydraulic oil is too hot (above 45°) .	Change the oil.
	The seal of the cylinder is abraded.	Replace the seal.
	Inside surface of the posts is not well greased.	Add grease.
Lowering too slow	The throttle valve jammed.	Clean or replace.
	The hydraulic oil is dirty.	Change the oil.
	The anti-surge valve jammed.	Clean it.
	The oil hose jammed.	Replace it.
The steel cable is abraded	No grease when installation or out of lifetime.	Replace it.

MAINTENANCE

Easy and low cost routine maintenance can ensure the lift work normally and safely. Following are requirements for routine maintenance. Frequency of routine maintenance is determined by working condition and frequency.

THE FOLLOWING PARTS ARE NEEDED TO BE LUBRICATED

S/N	Description
1	Up pulley
2	Steel cable
3	Chain wheel
4	Chain
5	Sliding block
6	Pin
7	Arm block
8	Lifting arm
9	Tray
10	Down pulley

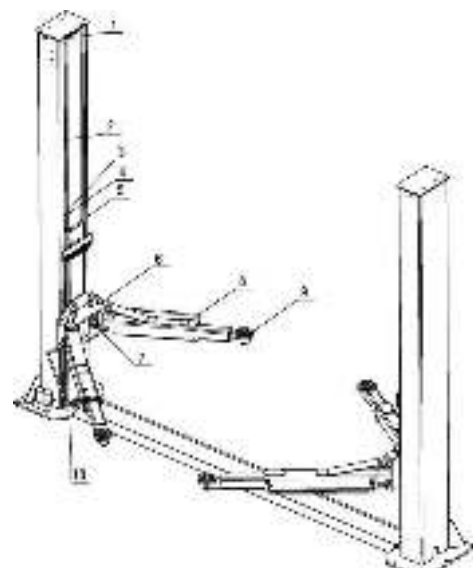

6.1 Daily checking items before operation

The user must perform daily check. Daily check of safety lock system is very important – the discovery of device failure before action could save time and prevent great loss, injury or casualty.

- Before operation, judge whether the safety locks are engaged by sound.
- Check whether oil hose well connected and whether it leaks or not.
- Check the connections of chain and steel cable and check the power unit.
- Check whether expansion bolts are firmly screwed.
- Check if arm lock works well or not.

6.2 Weekly checking items

- Check the flexibility of moving parts.
- Check the working conditions of safety parts.
- Check the amount of oil left in the oil tank. Oil is enough if the carriage can be raised to highest position. Otherwise, oil is insufficient.
- Check whether expansion bolts firmly screwed.

6.3 Monthly checking items

- Check whether expansion bolts are firmly screwed.
- Check the tightness of the hydraulic system and screw firm the joints if it leaks.
- Check the lubrication and abrasion circumstance of axial pins, carriages, lifting arms and other related parts and replace in time with new ones if they failed to work well.
- Check the lubrication and abrasion circumstance of steel cable.

6.4 Yearly checking items

- Empty the oil tank and check the quality of hydraulic oil.
- Wash and clean the oil filter.

If users strictly follow the above maintenance requirements, the lift will keep in a good working condition and meanwhile accidents could be avoided to a large extent.

ANNEX

Annex 1, Packing List of the whole lift

S/N	Name	Drawing#	Property	Qty
1	Power-side post	ON-7224G-A1	Assembly	1
2	Post	ON-7224G-A2	Assembly	1
3	Carriage	ON-7224G-A3	Assembly	2
4	Long arm	ON-7224-A7	Assembly	2
5	Short arm	ON-7224-A8	Assembly	2
6	Oil cylinder	ON-7224-A4-B2	Assembly	1
7	Drive oil cylinder	ON-7224-A4-B3	Assembly	1
8	Power unit		Assembly	1
9	Base cover plate	ON-7224-A10	Q235A	1
10	Slot base plate	ON-7224G-A9	Welded	1
12	Control box		Assembly	1
13	Steel cable	ON-7224-A6 L=8820mm	Assembly	2
14	Power unit package	825*245*312mm		1
15	The carton includes the following	850*340*130mm		1
16	Protection rubber pad	ON-7224-A3-B7	Rubber	2

17	Rubber oil hose	L=1300	Assembly	1
18	Rubber oil hose	L=2900	Assembly	1
19	Rod of the chain protection cloth	ON-7224-A13	Zinc-plating	4
20	Lifting tray	ON-7224-A7-B3	Assembly	4
21	Long arm fender	ON-7224-A7-B4	Powder-coating	2
22	Short arm fender	ON-7224-A8-B3	Powder-coating	2
23	Height adapter	ON-7224-A15	Zinc-plating	4
24	Shaft	ON-7224-A12	Zinc-plating	4
25	Chain protection cloth 2700	ON-7224-A11	Assembly	2
26	Braket for Adapter	ON-7224-A1-B4		
27	Oil pipe cover	ON-7224-A16		
28	Hex head full swivel screw	M6*30	Standard	4
29	Hex socket button head screw	M6*10	Standard	8
30	Hex socket button head screw	M8*12		
31	Cross socket flat head screw	M8*20	Standard	4
32	Cross socket cap head screw	M6*12	Standard	4
33	Class C flat washer	M6	Standard	8
34	Hex socket full screw	M8*35		
35	Class C flat washer	M8	Standard	4
36	Spring washer	M8	Standard	4
37	Hex nut	M8	Standard	4
38	Hex nut	M6	Standard	8
39	Circlip	38	Standard	4
40	Expansion bolt			

Annex2, Overall diagram

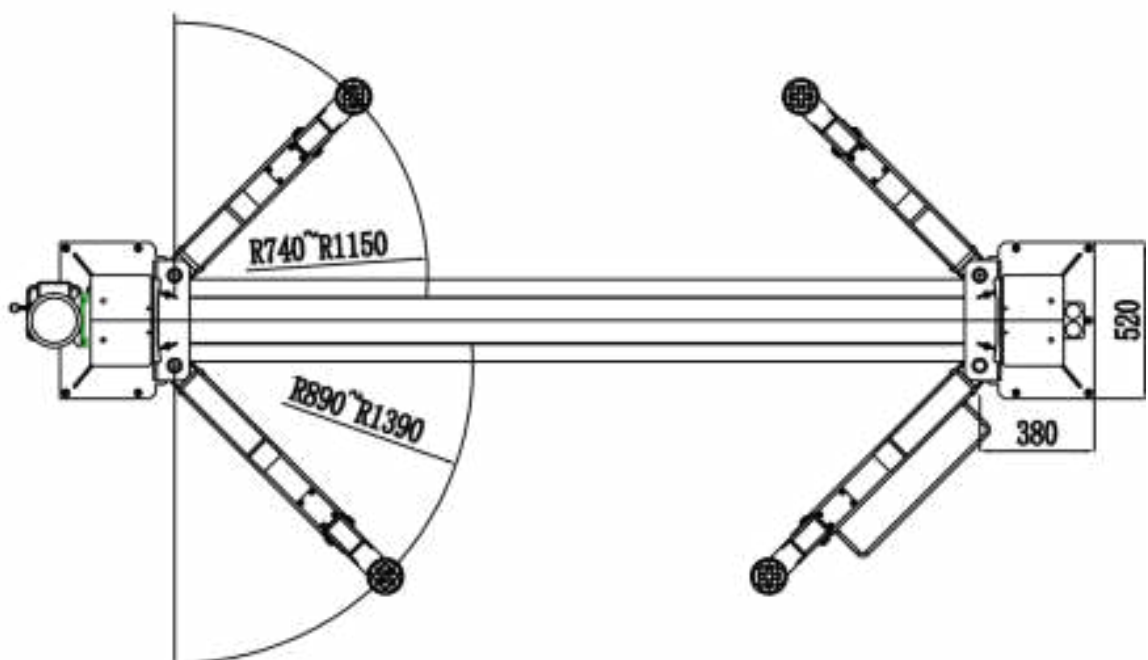
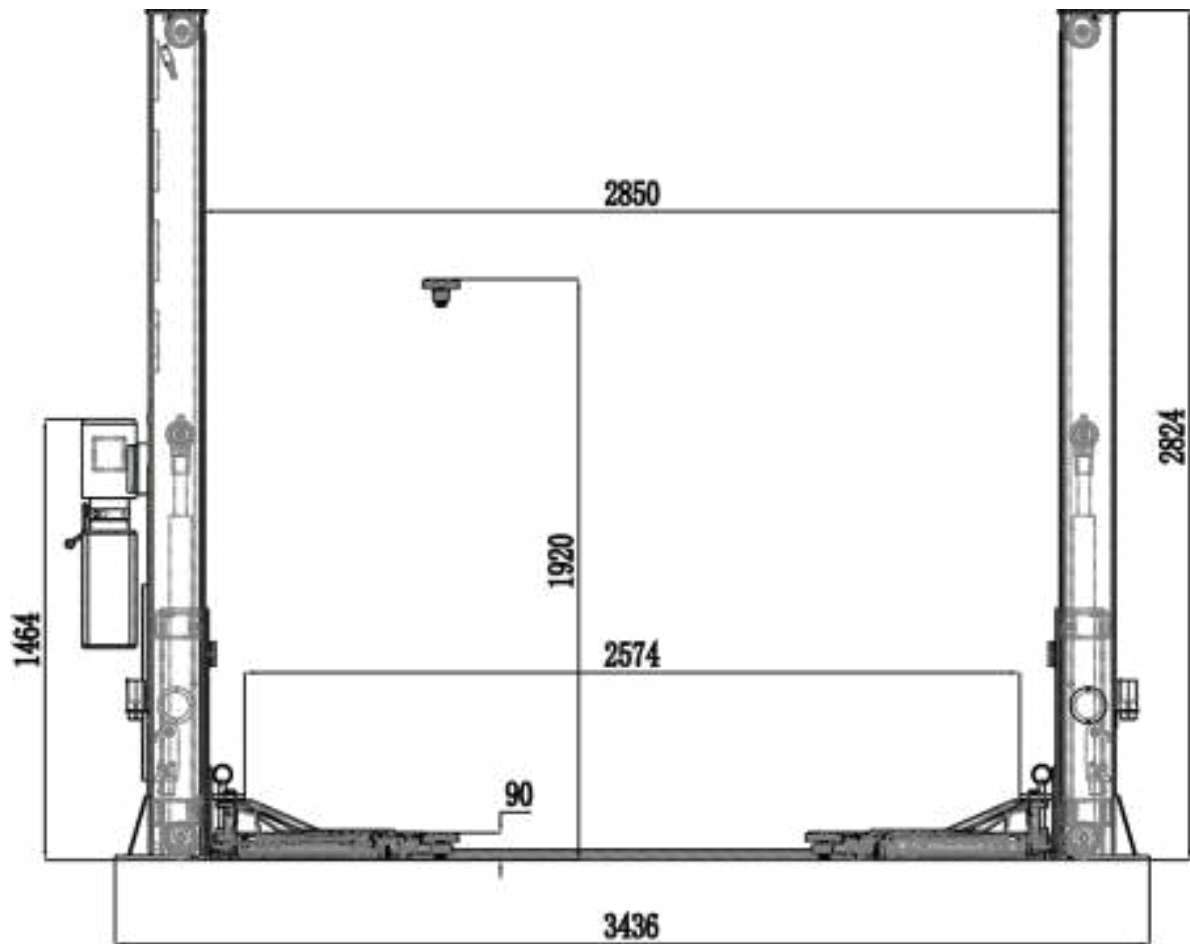

Annex3, Floor plan

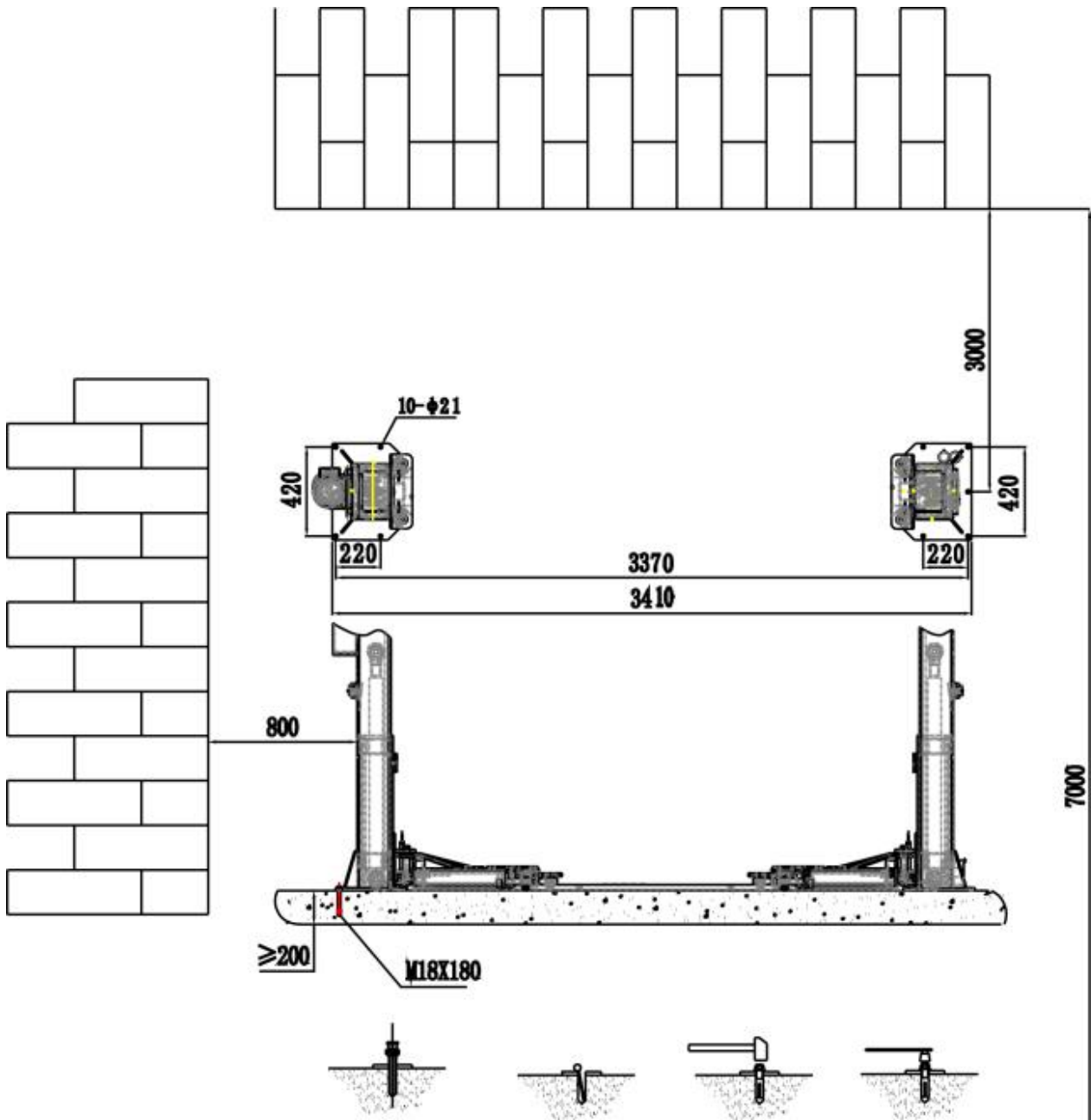

Technical requirements:

1. concrete class: 425#, 20days cure and reinforcement for newly built ground.
2. Concrete thickness > 200mm
3. Evenness < 5mm
4. Thickness and evenness of the concrete is very important, you may not expect too much of the levelling ability of the lift itself.

Annex 4, Hydraulic working system

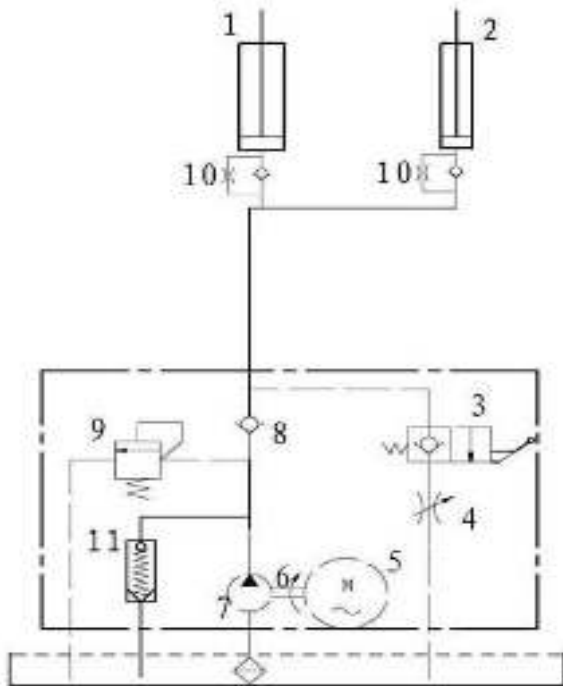

1. Drive oil cylinder
2. Assistant oil cylinder
3. Manual unloading valve
4. Throttle valve
5. Motor
6. Coupling
7. Gear pump
8. Single –way valve
9. Over-flow valve
10. Anti-surge valve
11. Cushion valve

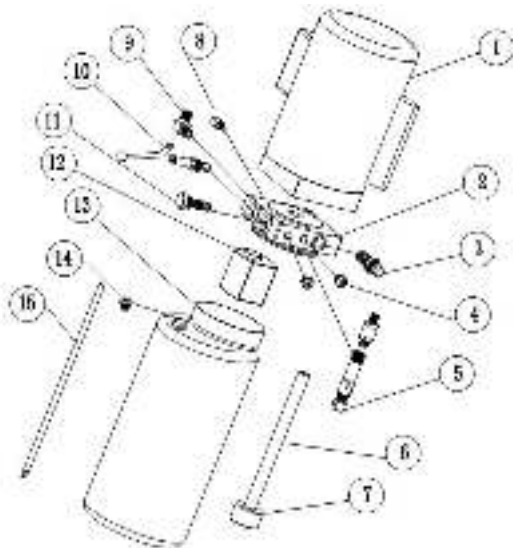

S/N	Name	Qty
1	Motor	1
2	Hydraulic block	1
3	Overflow valve	1
4	Removable plug	2
5	Cushion valve	1
6	Oil absorbing pipe	1
7	Oil filter	1
8	Throttle valve	1
9	Oil pipe tie-in	1
10	Unloading valve	1
11	One-way valve	1
12	Gear pump	1
13	Plastic oil tank	1
14	Oil tank cover	1
15	Oil back pipe	1

Annex5, Wiring diagram

Single phase

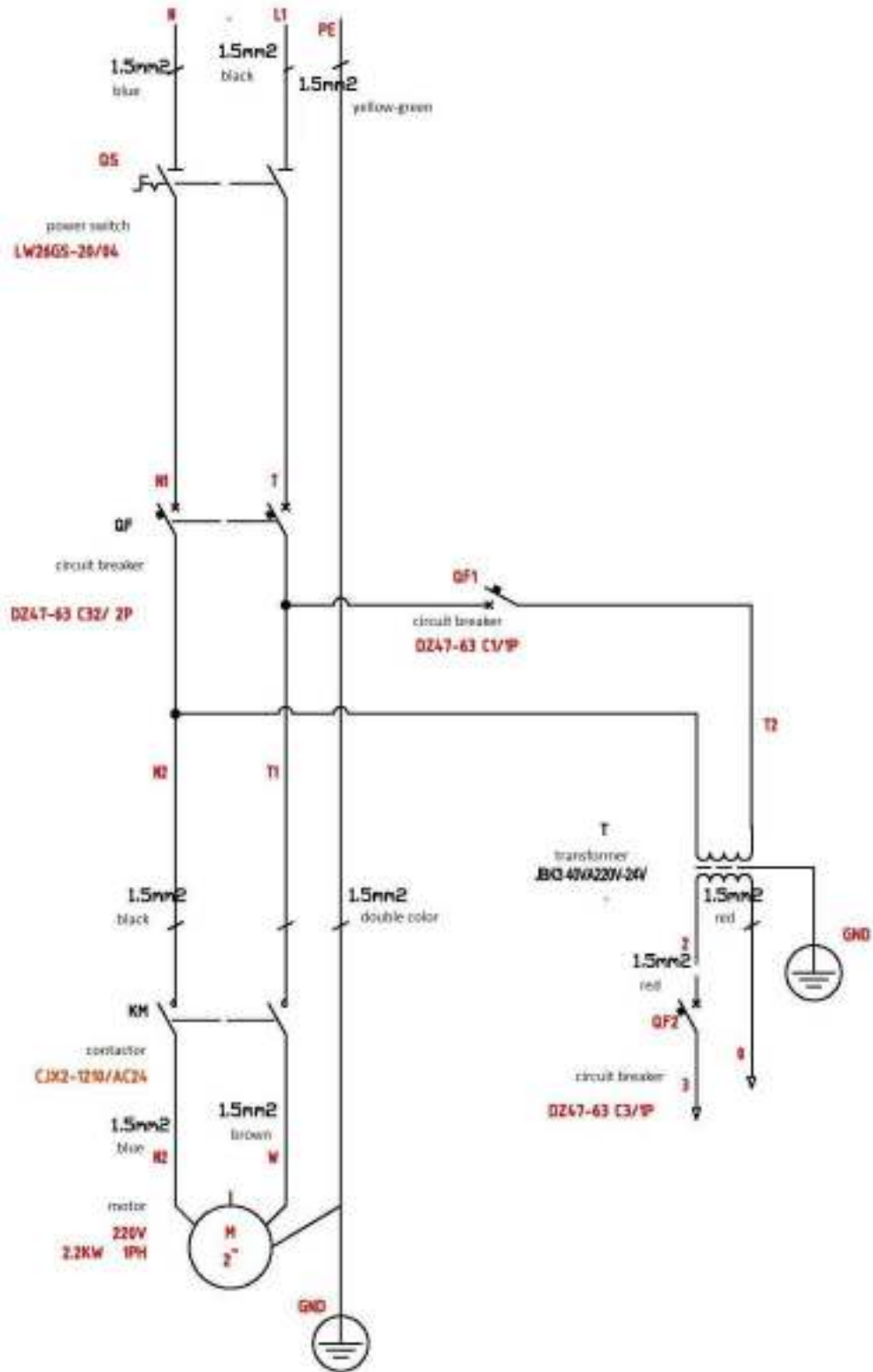

Three phase

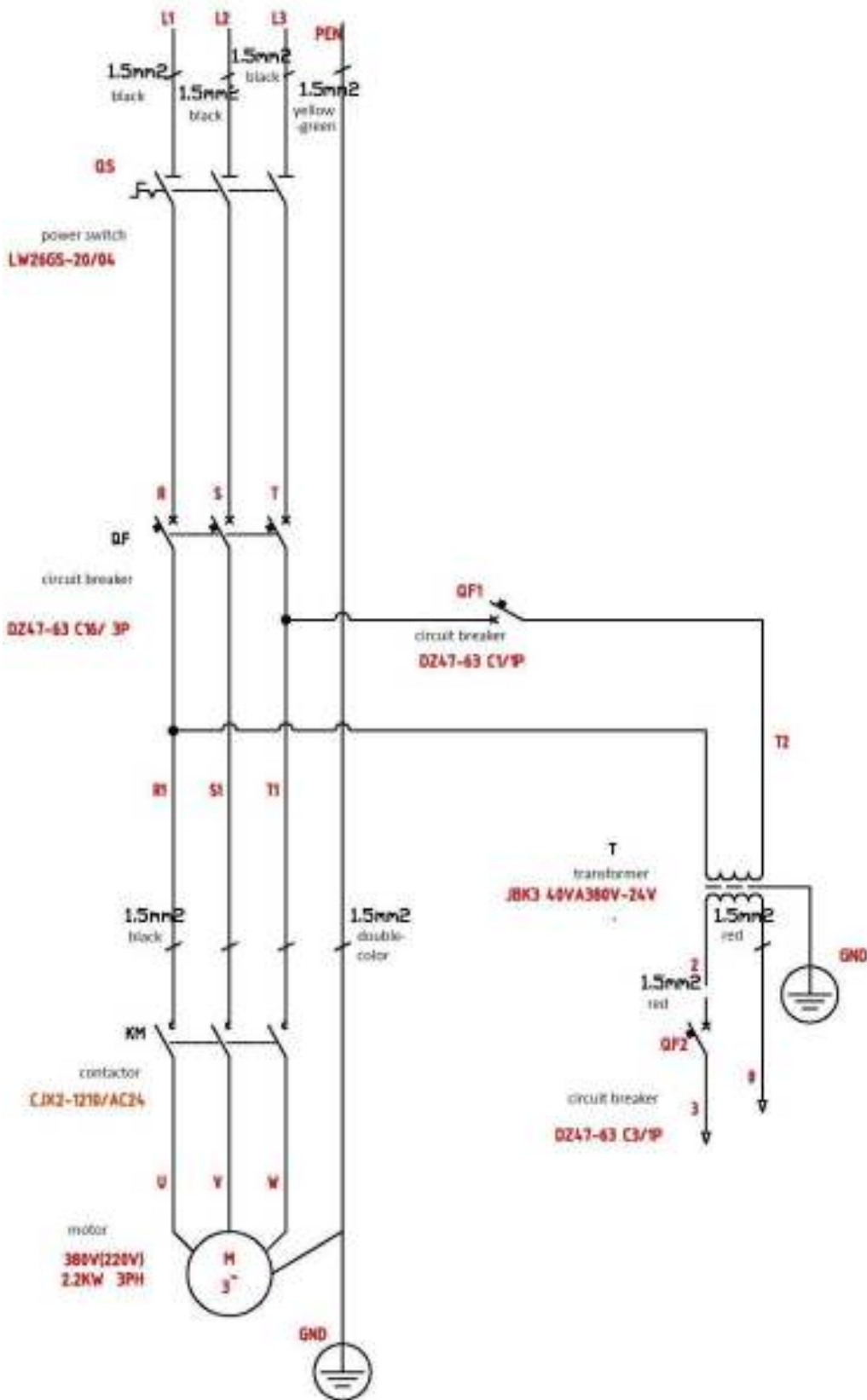

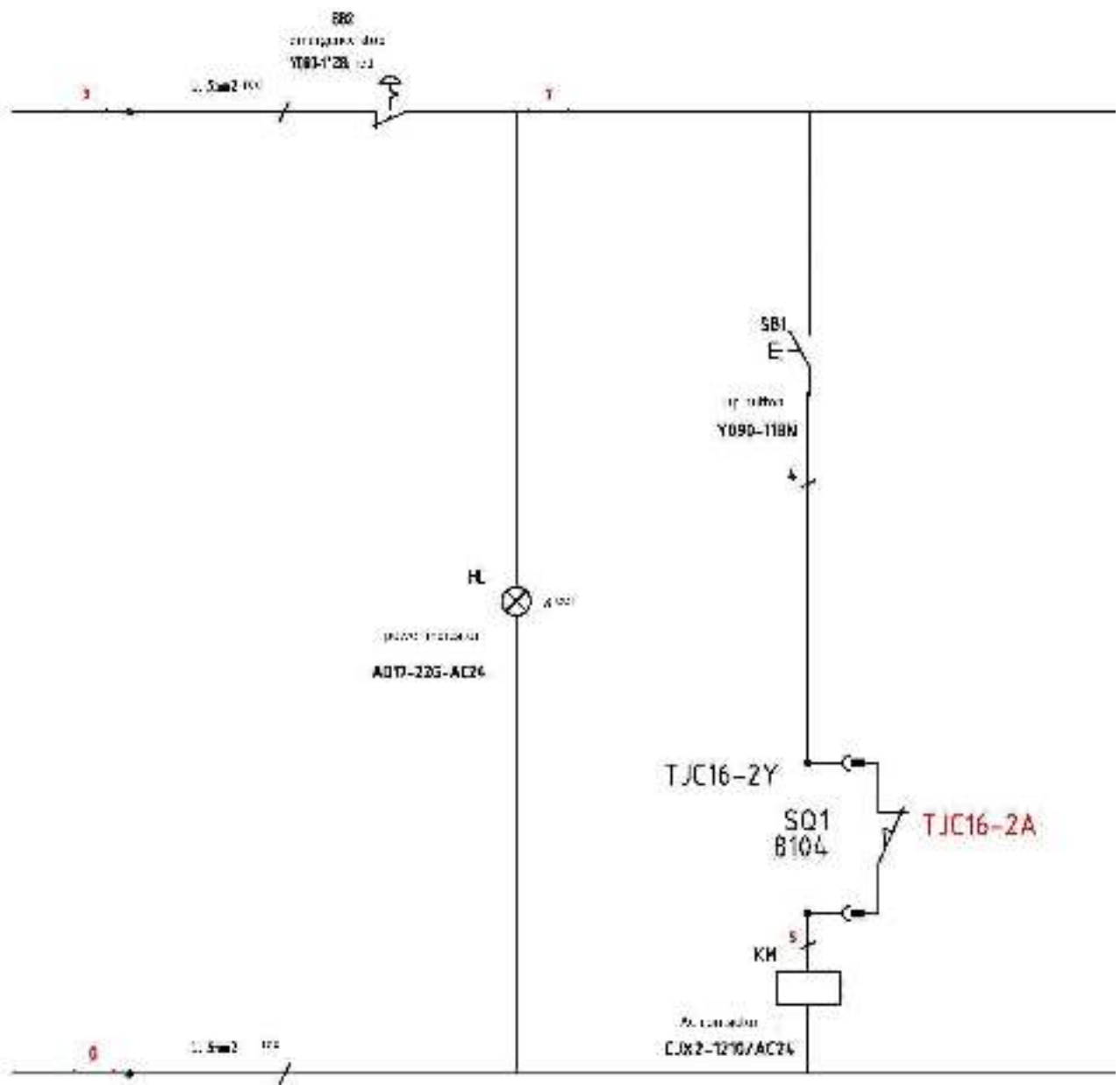

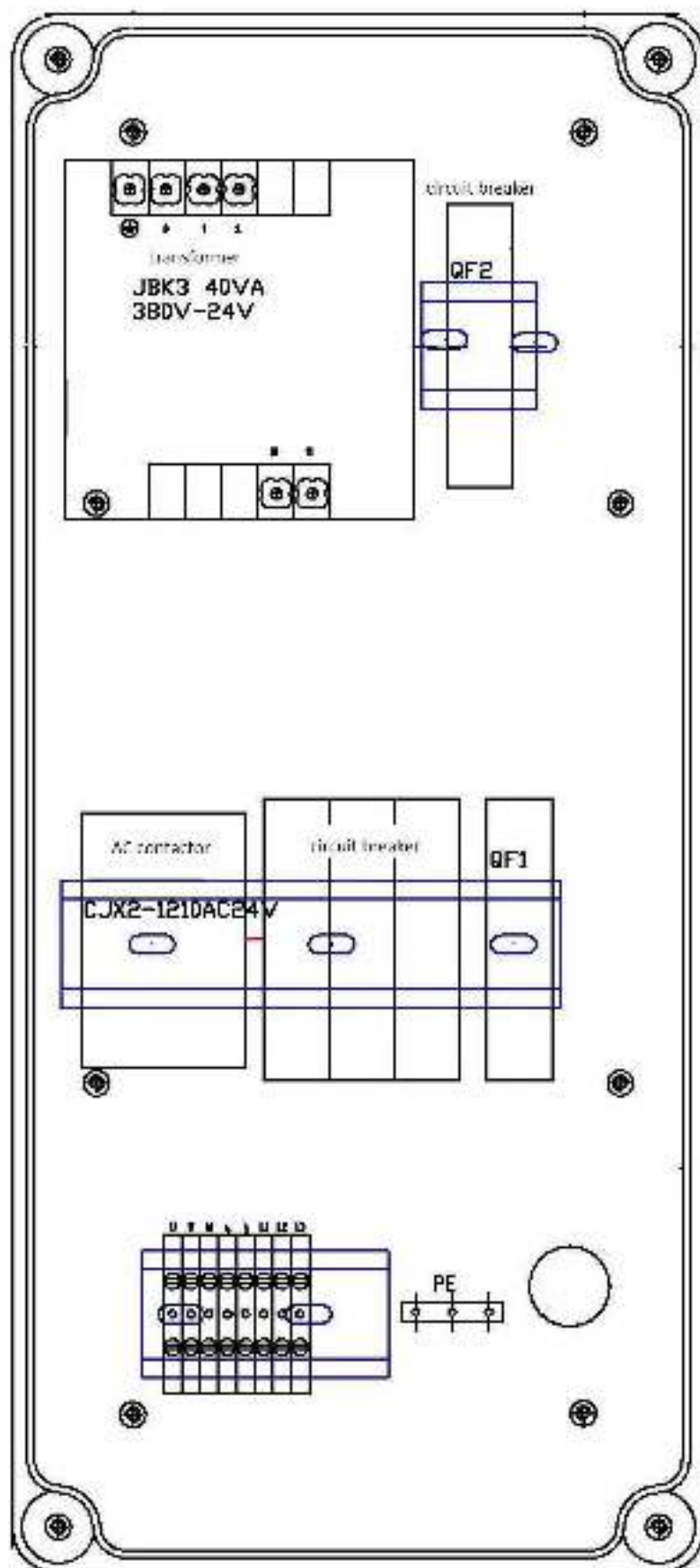

Annex 6, Separated drawings for the lift

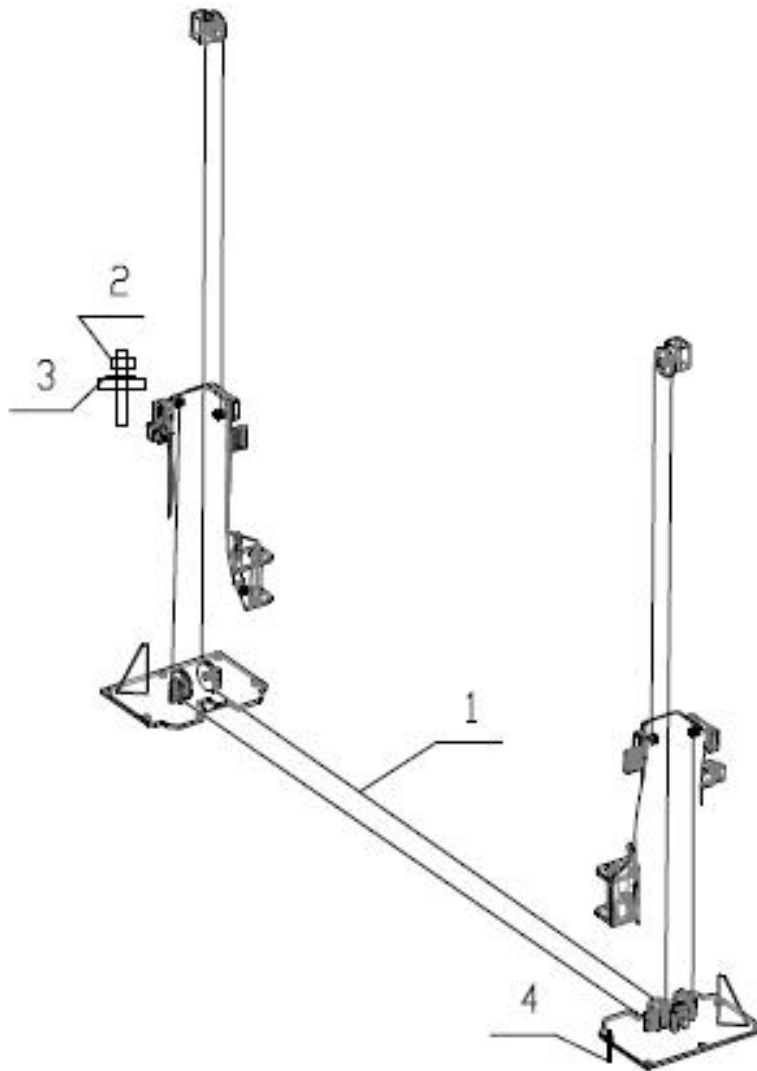

S/N	Name	Drawing#	Qty	Property	Note
1	Steel cable L=8820mm	ON-7224-A6	2	Assembly	
2	Hex nut M16	GB/T6170-2000	8	Standard	
3	Class C flat washer M16	GB/T95-1985	4	Standard	
94	Expansion bolt M18*180		10	Standard	

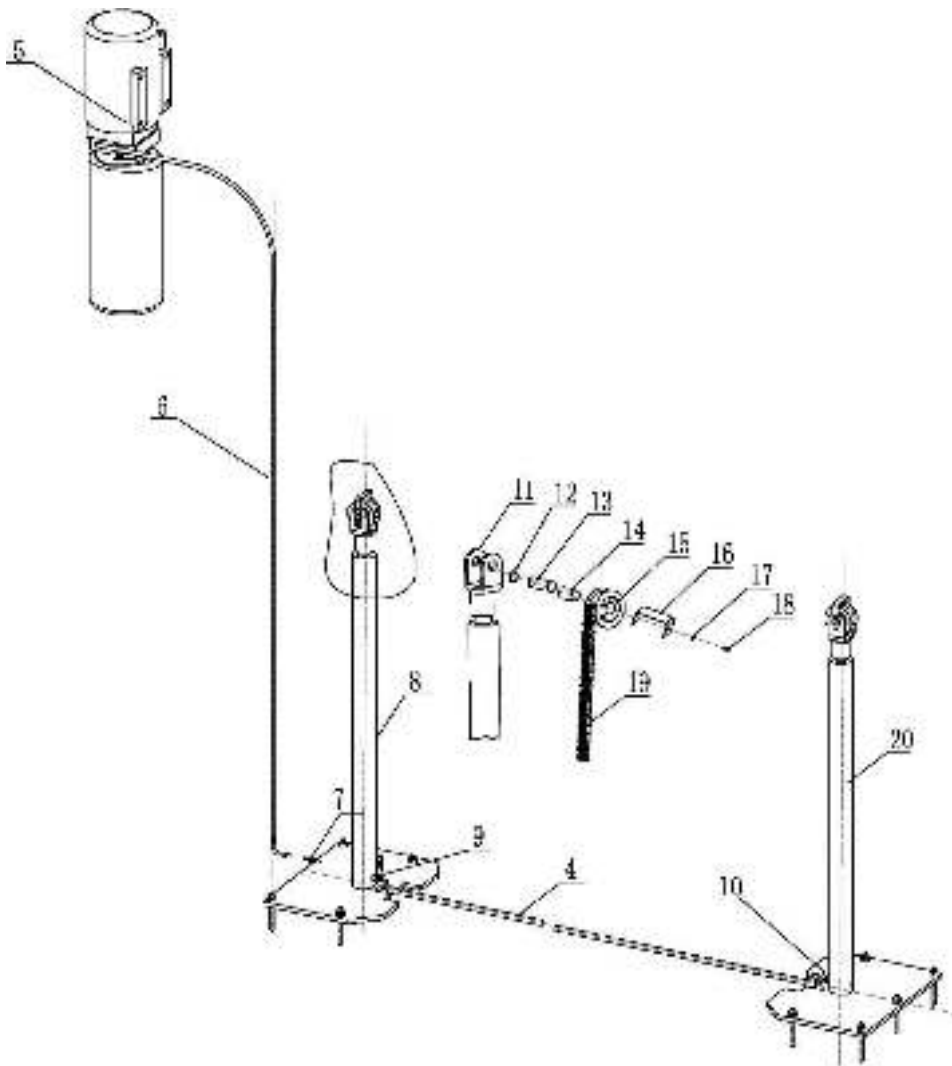

S/N	Name	Drawing#	Qty	Property	Note
4	Rubber oil hose L=2900		1	Assembly	
5	Power unit		1	Assembly	
6	Rubber oil hose L=1300		1	Assembly	
7	Long connector		2	Assembly	
8	Drive oil cylinder	ON-7224G-A4-B2	1	Assembly	
9	Main connector		1	Zinc-plating	
10	Short connector		1	Zinc-plating	
11	Chain wheel bracket	ON-7224-A4-B9	2	Zinc-plating	
12	Type B circlip 25	GB/T894.2-1986	4	Standard	
13	Chain wheel shaft	ON-7224-A4-B11	2	Zinc-plating	
14	Bearing 2548	SF-1	2	Standard	
15	Chain wheel	ON-7224-A4-B10	2	Zinc-plating	
16	Retaining plate	ON-7224-A4-B12	2	Zinc-plating	
17	Spring washer M6	GB/T93-1987	4	Standard	
18	Hex socket cylinder head screw M6*10	GB/T70.1-2000	4	Standard	
19	Chain	LH1234-127LGB/6074-1995	2	Standard	
20	Oil cylinder	ON-7224G-A4-B3	1	Assembly	

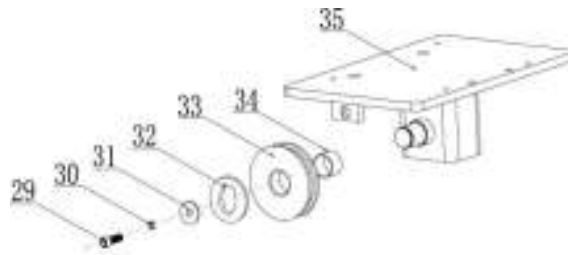

S/N	Material #	Name	Drawing#	Qty	Property	Note
29		Hex socket button head screw M8*20	GB/T70.2-2000	2	Standard	
30		Spring washer M8	GB/T93-1987	2	Standard	
31		Retaining ring	ON-7224-A1-B3-C2	2	Zinc-plating	
32		Washer	GB/T894.2-1986	2	Zinc-plating	
33		UP pulley	ON-7224-A1-B2	2	Zinc-plating	
34		Bearing 2518	SF-1	2	Standard	
35		Top cover	ON-7224-A1-B3-C1	2	Welded	

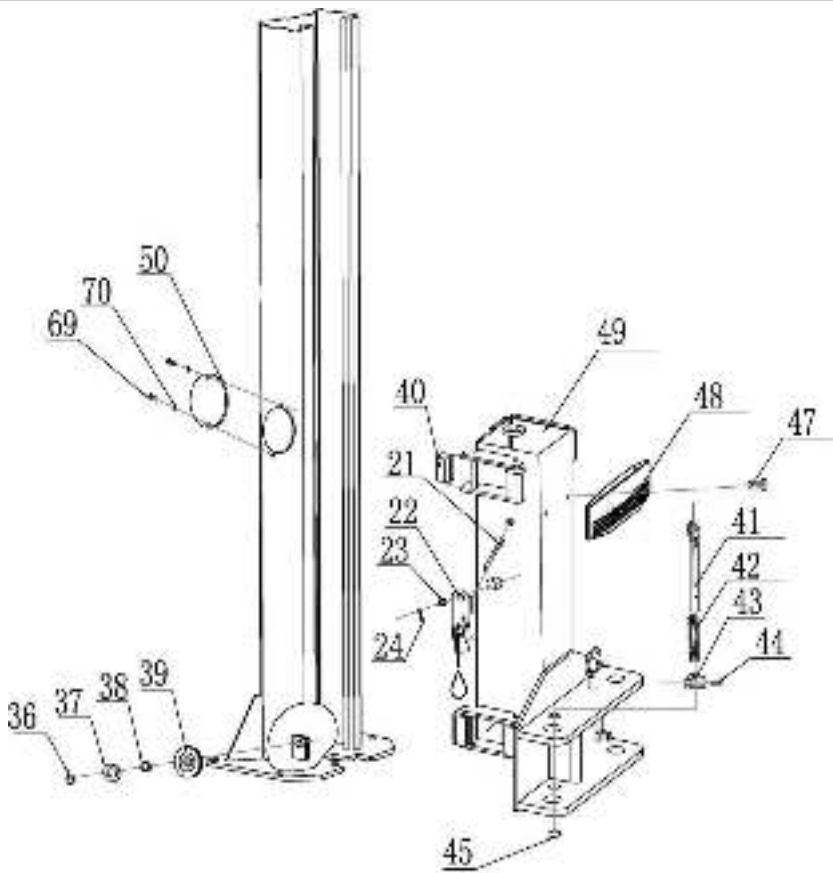

S/N	Name	Drawing#	Qty	Property	Note
21	Tension spring	ON-7224-A3-B8	2	65Mn	
22	Safety lock assembly	ON-7224-A3-B3	2	Assembly	
23	Sheath			Q235A	
24	Cotter pin 3*45	GB/T879.1-2000	2	Standard	
36	Type B circlip 25	GB/T894.2-1986	4	Standard	

S/N	Name	Drawing#	Qty	Property	Note
37	Washer			Q235A	
38	Bearing 2512	SF-1	4	Standard	
39	Down pulley	ON-7224-A1-B3	4	Q235A	
40	Slider	ON-7224G-A3-B6	16	Nylon 1010	
41	Pulling rod	ON-7224-A3-B2	4	Welded	
42	Pressure spring	ON-7224-A3-B5	4	Zinc-plating	
43	Teeth block	ON-7224-A3-B4	4	Q235A	
44	Elastic cylindrical pin 5*35	GB/T879.1-2000	4	Standard	
45	Type B circlip 25	GB/T894.2-1986	2	Standard	
47	Cross socket sunken head screw M8*16	GB/T819.1-2000	4	Standard	
48	Protection rubber pad	ON-7224-A3-B7	2	Rubber	
49	Carriage	ON-7224-A3-B1	2	Assembly	
50	Cover plate	ON-7224-A1-B5	2	Q235A	
69	Cross socket cap head screw M6*8	GB/T818-2000	4	Standard	
70	Class C flat washer M6	GB/T95-1985	4	Standard	

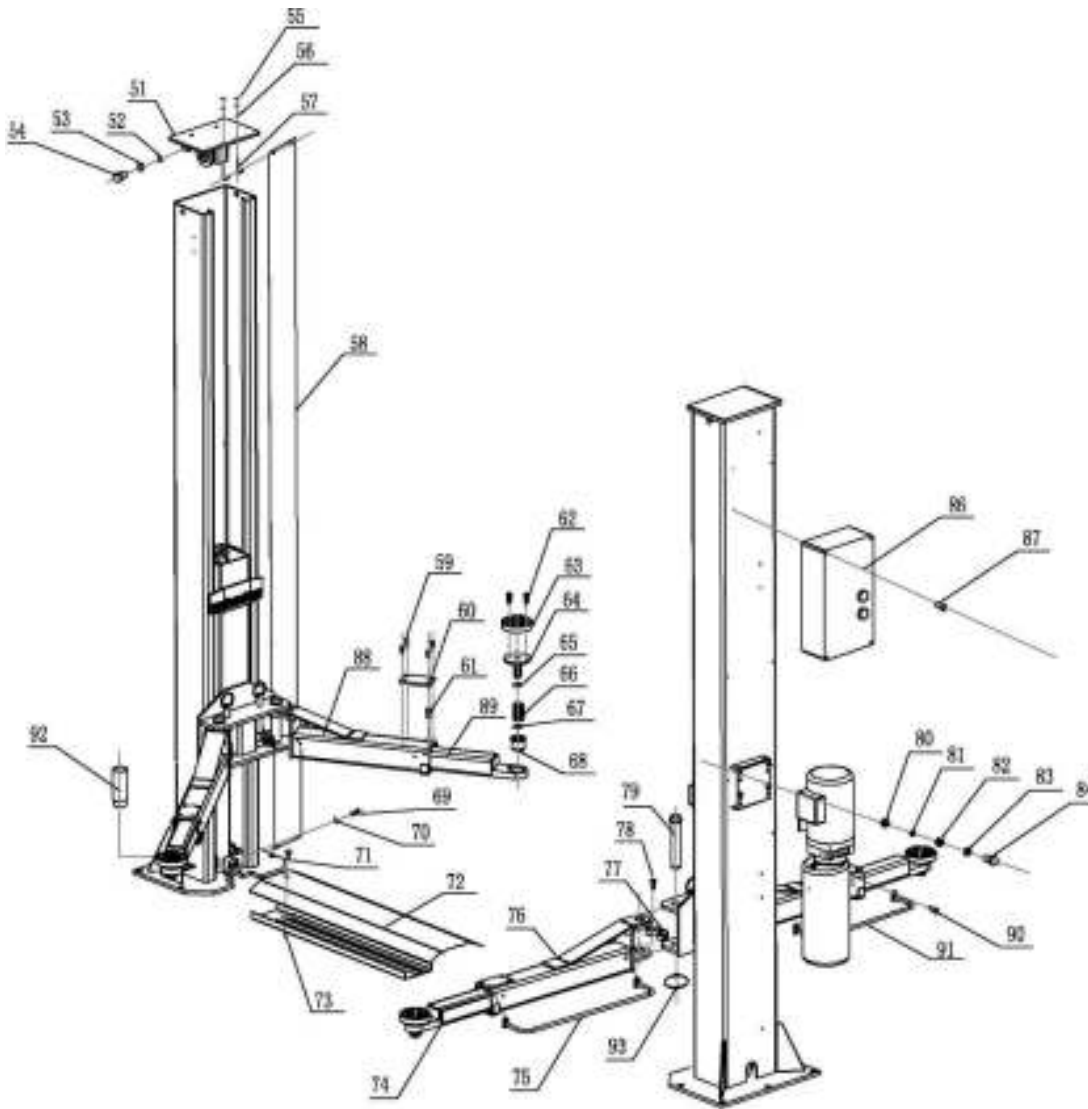

S/N	Name	Drawing#	Qty	Property	Note
51	Top plate	ON-7224-A1-B3	2	Assembly	
52	Class C flat washer M12	GB/T95-1985	4	Standard	
53	Spring washer M12	GB/T93-1987	4	Standard	
54	Hex head full swivel screw M12*20	GB/T5781-2000	4	Standard	
55	Hex nut M6	GB/T6170-2000	8	Standard	
56	Class C flat washer M6	GB/T95-1985	4	Standard	
57	Rod of chain protection cloth	ON-7224-A13	4	Standard	
58					
59	Cross socket flat head screw M5*10	GB/T819.1-2000	16	Standard	
60	Square lifting pad	ON-7224-A7-B6	4	Rubber	
61	Cross socket flat head screw M8*10	GB/T819.1-2000	4	Standard	
62	Hex socket flat head screw M8*20	GB/T70.3-2000	8	Standard	
63	Round lifting pad	ON-7224-A7-B3-C4	4	Rubber	
64	Lifting tray	ON-7224-A7-B3-C1	4	Welded	
65	Type B circlip 22	GB/T894.2-1986	4	Standard	
66	Swivel sheath	ON-7224-A7-B3-C2	4	Q235A	
67	Circlip 38*2.5	GB/T895.2-1986	8	Standard	
68	Inside swivel sheath	ON-7224-A7-B3-C3	4	Q235A	
69	Cross socket cap head screw M6*8	GB/T818-2000	4	Standard	
70	Class C flat washer M6	GB/T95-1985	4	Standard	
71	Hex socket flat head screw M12*20	GB/T70.3-2000	2	Standard	
72	Base cover plate	ON-7224-A10	1	Q235A	
73	Slot base plate	ON-7224G-A9	1	Welded	
74	Long tensile arm	ON-7224-A7-B1	2	Welded	
75					
76	Long arm	ON-7224-A7-B2	2	Welded	
77	Teeth block	ON-7224-A7-B5	4	Q235A	
78	Hex socket cylinder head screw M10*20	GB/T70.1-2000	12	Standard	
79	Pin	ON-7224-A12	4	Welded	
80	Hex nut M10	GB/T6170-2000	4	Standard	
81	Spring washer M10	GB/T93-1987	4	Standard	
82	Anti-shock pad	ON-7224-A14	4	Rubber	
83	Class C flat washer M10	GB/T95-1985	4	Standard	
84	Hex head full swivel screw M10*35	GB/T5781-2000	4	Standard	
86					
87					
88	Short arm	ON-7224-A8-B1	2	Welded	
89	Short tensile arm	ON-7224-A8-B2	2	Welded	
90	Hex socket button head screw M8*12	GB/T70.2-2000	8	Standard	
91					
92	Height adapter	ON-7224-A15	4	Welded	

Annex 7, Spare parts list

Spare parts list---mechanical part

S/N	Name	Drawing#	Qty	Property	Note
1	Slider	ON-7224-A3-B6	16	Nylon 1010	
2	Rubber lifting pad	ON-7224-A7-B3-C4	4	Rubber	
3	Y-shape seal ring	23.6*3.55	1		
4	O-shape seal ring	KD 63*48*10	1		
5	Anti-dust ring	DHS 40*48*5/6.5			