

USE AND MAINTENANCE MANUAL

PX8 HELPER

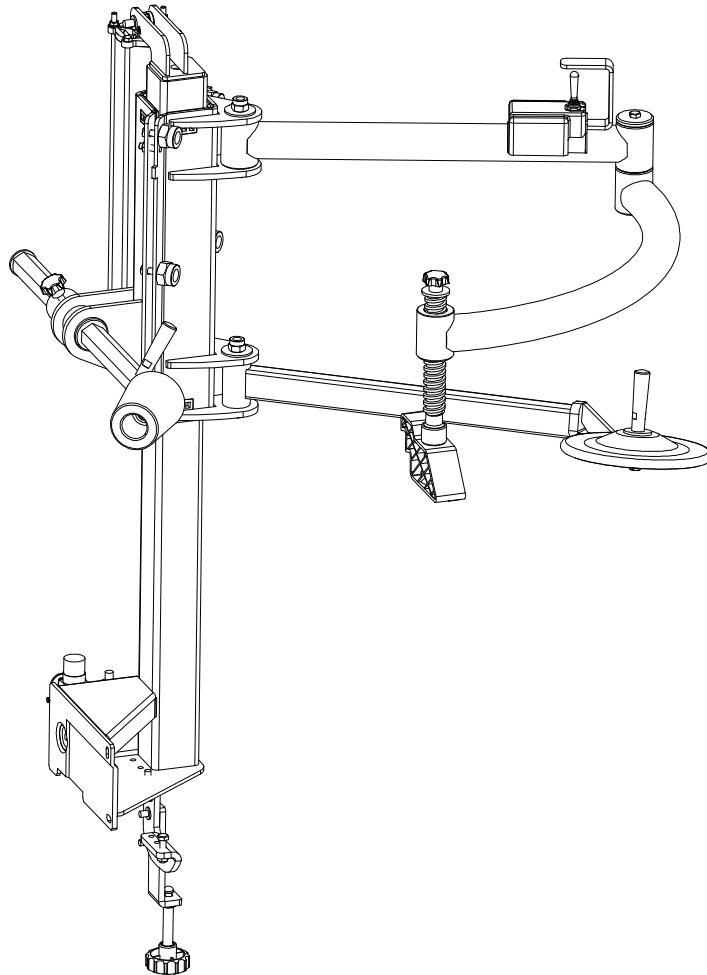

CONTENTS

1	INTRODUCTION	3
2	PRODUCT DESCRIPTION	4
3	GENERAL INFORMATION	5
4	INSTALLATION	6
5	USE	9
6	MAINTENANCE	11

CHAPTER 1 - INTRODUCTION

Thank you for purchasing a product from the line of accessories. The machine has been manufactured in accordance with the very best quality principles. Follow the simple instructions provided in this manual to ensure the correct operation and long life of the machine. Read the entire manual thoroughly and make sure you understand it.

IDENTIFICATION DATA

A complete description of the “Model” and the “Serial number” will make it easier for our technical assistance to provide service and will facilitate delivery of any required spare parts. For clarity and convenience, we have inserted the data of your tyre changer in the box below. If there is any discrepancy between the data provided in this manual and that shown on the plate fixed to the machine, the latter should be taken as correct.

This manual is an integral part of the product. Before using the tyre changer, read carefully the warnings and instructions contained in this manual since they provide important information on operating safety and maintenance.



Keep this manual for future reference.

CHAPTER 2 - PRODUCT DESCRIPTION

- 1) Arm 1
- 2) Lifting/lowering control
- 3) Bead pressing arm
- 4) Bead pressing tool
- 5) Bead lifting disk
- 6) Operating arm with bead lifting disk
- 7) Roller tool
- 8) Operating arm with roller tool

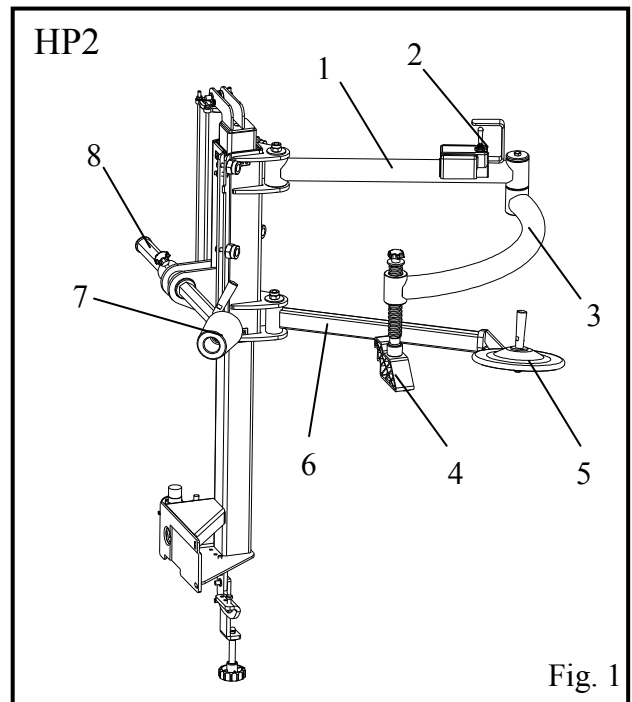

CHAPTER 3 – GENERAL INFORMATION

3.1 INTENDED USE

These accessories have been designed and manufactured exclusively for being installed on a tire changer in order to facilitate removing and mounting of tires from/onto the rim.



In particular the manufacturer cannot be held responsible for any damage caused through the use for purposes other than those specified in this manual, and therefore inappropriate, incorrect and unreasonable.

3.2 GENERAL SAFETY RULES

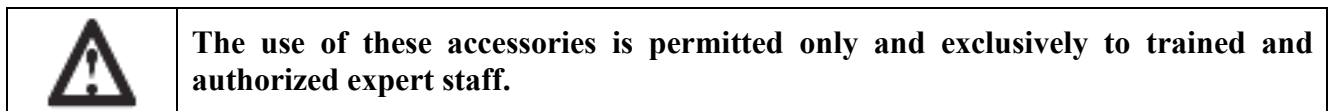

Any tampering or modification to the equipment carried out without the manufacturer's prior authorization will free him from all responsibility for damage caused directly or indirectly by the above actions.

Removing or tampering with safety devices immediately invalidates the warranty.

3.3 TRANSPORTATION

The accessories must be transported in their original package and kept in the position shown on the package itself.

The packaged accessories may be moved by means of a forklift truck of suitable capacity.

3.4 UNPACKING

Once the packing material has been removed, check the machine visually for any signs of damage.

Keep the packing materials out of the reach of cylinder as they can be a source of danger.

Keep the packing for possible future transport.

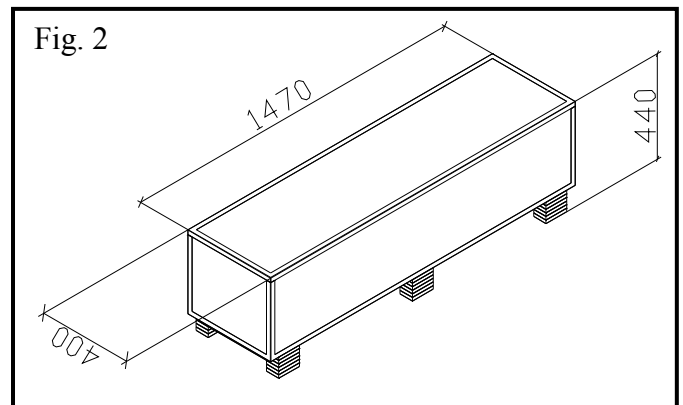

CHAPTER 4 – INSTALLATION

The accessories need to be connected to a compressed air system with values between 8 – 10bar.

4.1 INSTALLATION ON TIRE CHANGER

- Unscrew the lubricator support (fig. 3 ref. A);
- Set the HP2 support plates (D) in relevant holes and fix them by means of nuts M10 (fig. 4);
- Mount HP2 onto the supports and fix it by means of nuts M10 (E);
- Fix the lubricator support (if any) by screws to the HP2 body;
- Fix the lubricator to its support (if any) or directly to the HP2 body.

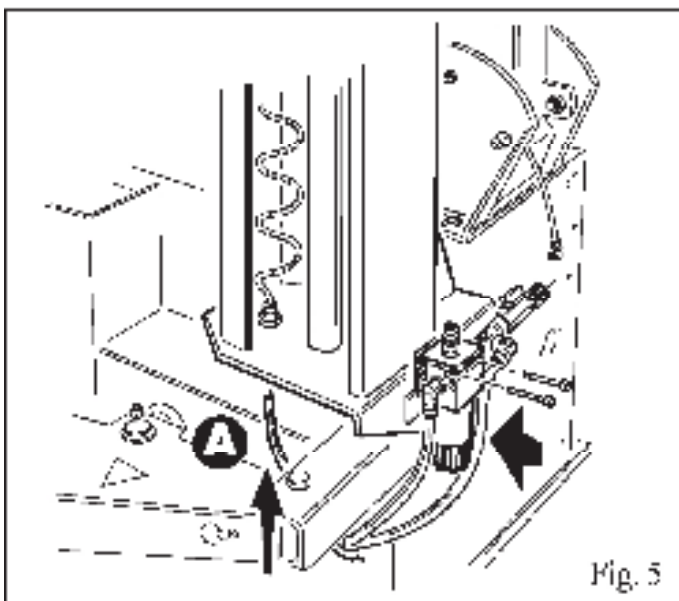
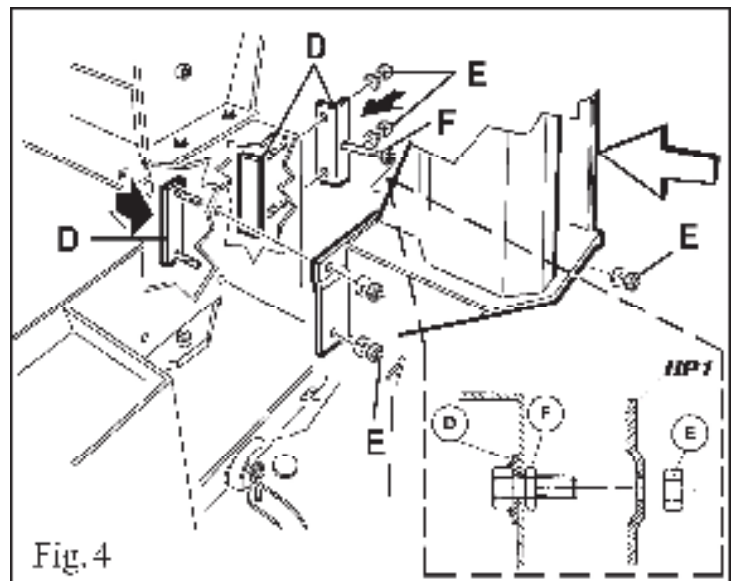
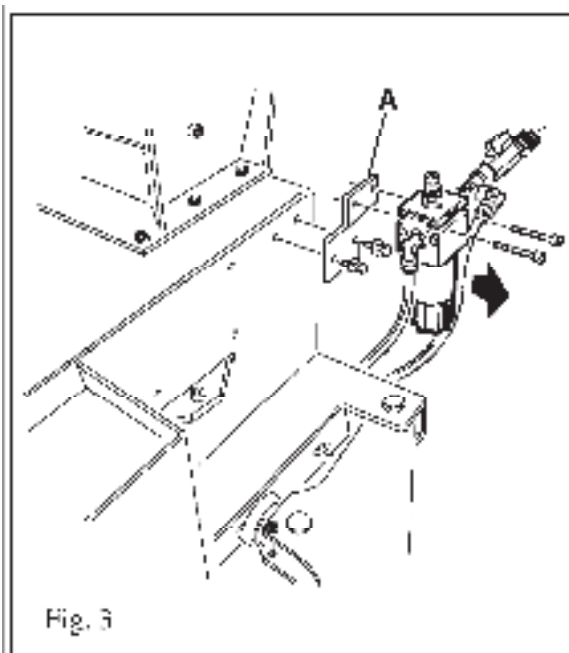

4.2 PNEUMATIC CONNECTION TO TIRE CHANGER

- Cut the feeding Rilsan hose (fig. 6) at about 5cm from the regulator (if any);
- Connect the union, delivered with the kit, into the cut hose;
- Connect the hose coming from HP2 into the quick union;
- Make sure the hose fit the union properly.
- Make sure that the feeding hose of HP2 is correctly connected into the union under the base frame (fig. 7, ref. A)

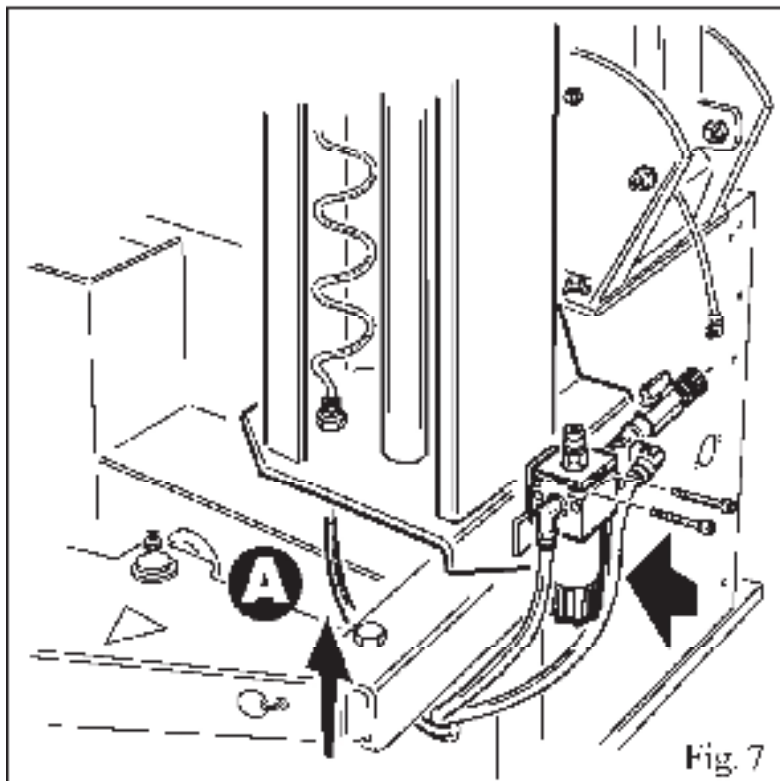
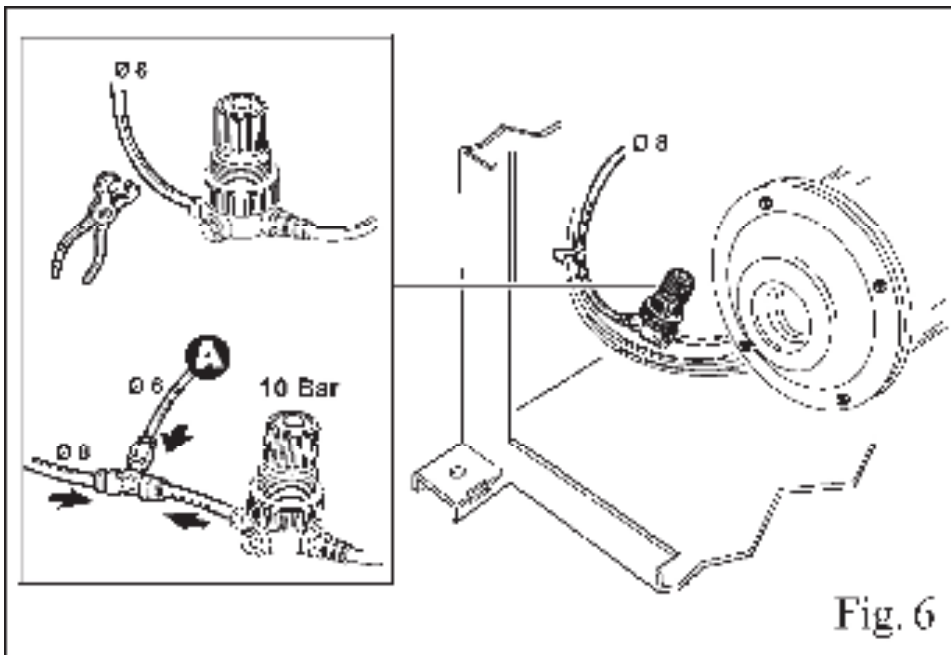

4.3 COMPONENTS ASSEMBLY

- Fit the bead pressing arm (H) into the pin and fix it adequately by means of screws and the washers (I).
- Apply the same procedure for mounting the disk arm (L) and fix it by means of screws and washers (M).
- Set the roller arm (N) into its housing and fix it by means of screws (P).

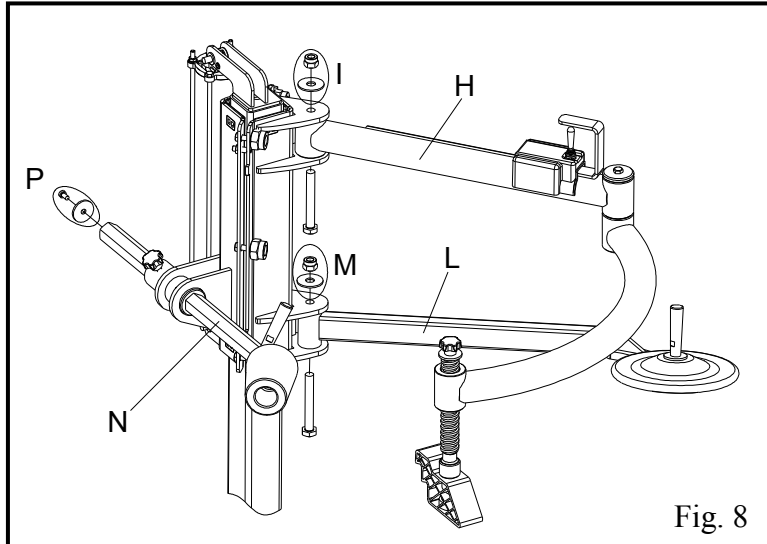

Fig. 8

CHAPTER 5 – USE

5.2 REMOVAL OF EXTRALOW PROFILED TIRES OR RACING TIRES

5.2.1 UPPER BEAD

- Lock the rim onto the turntable as shown in tire-changer's installation, use and maintenance guide;
- In case of difficulty, use the bead pressing tool (4) to keep the rim pressed onto the turntable clamps and facilitate its locking (if necessary, use a central cone to facilitate the operation) (fig. 9);
- Position the mounting head as indicated by standard proceeding for tire removal inside the installation, use and maintenance guide (if necessary, press roller against the tire to facilitate the operation) against the tire to facilitate the operation) (fig. 8);
- Position (fig. 10) the roller at the right side of the mounting head and the bead pressing tool (4)(fig. 11) at the opposite side, so that they press slightly the tire downwards, in order to facilitate introduction of the bead-lifting lever (Y);
- Position the bead pressing tool (4) (fig. 11) at the tool opposite side to facilitate the tire bead positioning on the mounting head by means of the bead lifting lever (Y);
- Once the lever is down and the bead is set onto the tool follow the standard removing procedure.

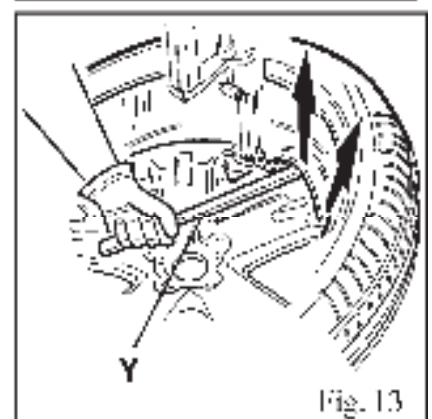
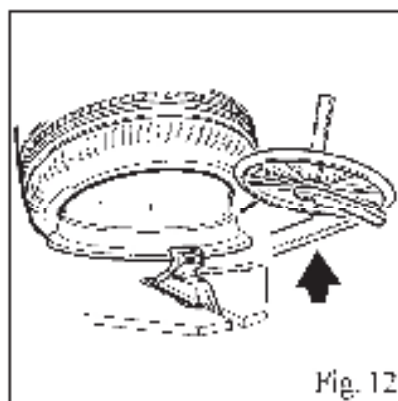
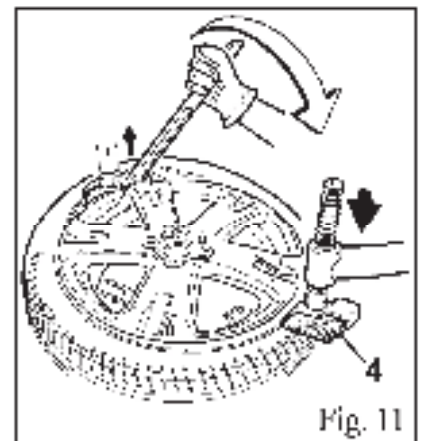
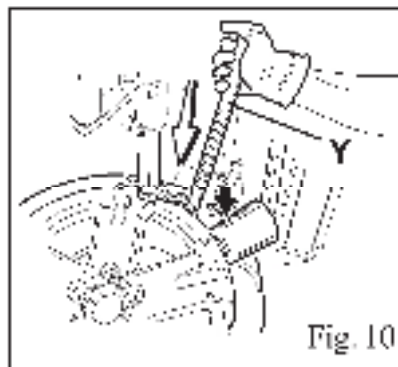
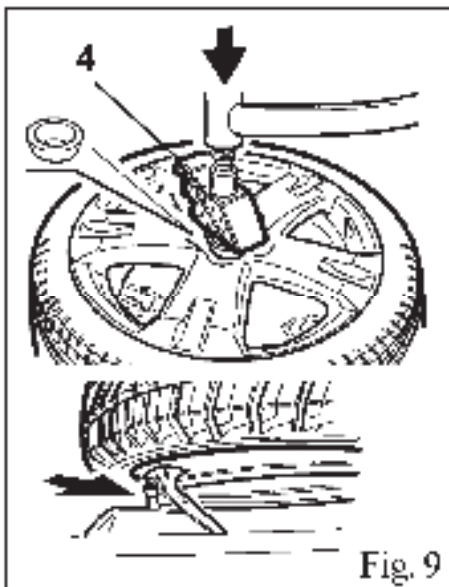

5.2.2 LOWER BEAD

- Follow standard proceedings for tire final removal and use the bead-lifting disks for keeping the tire at the same level of rim's groove (fig. 12). This will facilitate tire beading positioning on the tool by means of the bead-lifting (fig. 13).

5.3 MOUNTING EXTRALOW PROFILED TIRES OR RACING TIRES

5.3.1 LOWER BEAD

- Follow standard proceedings described in the installation, use and maintenance guide of tire changer.

5.3.2 UPPER BEAD

- Position the tire as described by standard proceedings inside the installation, use and maintenance guide of tire changer;
- Position the roller (8) and the bead pressing tool (4) at the right side of the mounting head (X) in a way that tire upper bead stays at the same level of rim's groove (fig. 13);
- Let the turntable turn until the tire is completely mounted (fig. 21);
- Release HP2.

 **If, during operation, the bead pressing tool (4) is not pressed adequately (too much or too few), it is necessary to adjust its height by the screwing the screw as shown in the figure 15.**

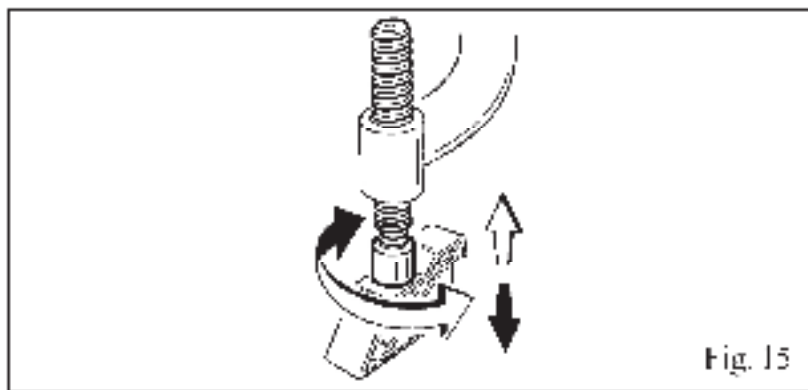
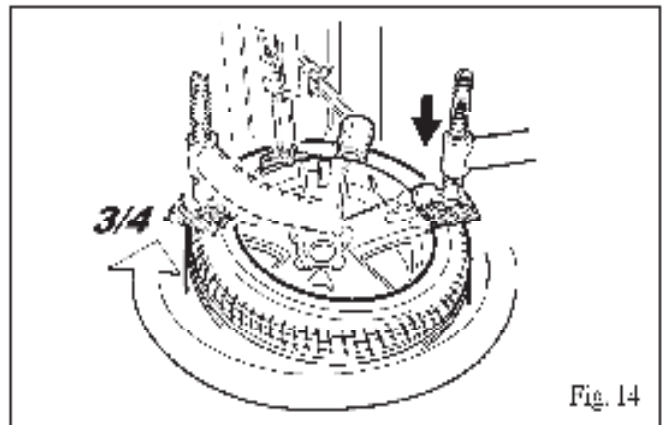
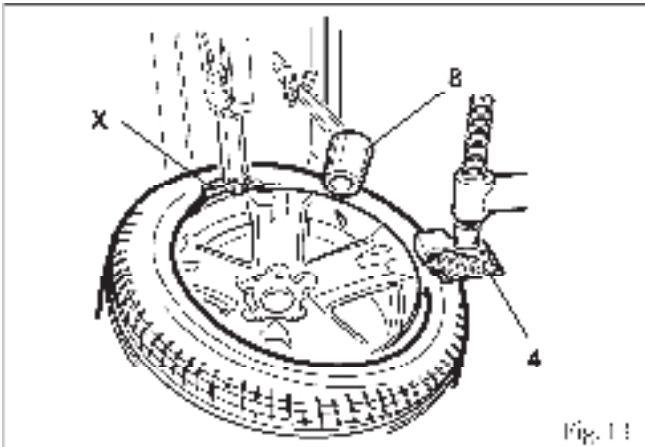

CHAPTER 6 – MAINTENANCE



Unauthorized person is forbidden to carry out maintenance work.

- Regular maintenance as described in the manual is essential for correct operation and long lifetime of the tire changer.
- If maintenance is not carried out regularly, the operation and reliability of the machine may be compromised, thus placing the operator and anyone else in the vicinity at risk.



Before carrying out any maintenance work, disconnect the electric and pneumatic supplies. Moreover, it is necessary to break the bead without load 3-4 times in order to let the air in pressure go out of the circuit.

- Defective parts must be replaced exclusively by expert personnel using the manufacturer's parts.
- Removing or tampering with safety devices (pressure limiting and regulating valves) is extremely forbidden.



In particular the Manufacturer shall not be held responsible for complaints deriving from the use of spare parts made by other manufacturers or for damage caused by tampering or removal of safety systems.

- Clean and grease weekly the sliding guides.
- For the rest, make reference to the installation, use and maintenance guide of tire changer, on which HELP and PRESS ARM are mounted.