

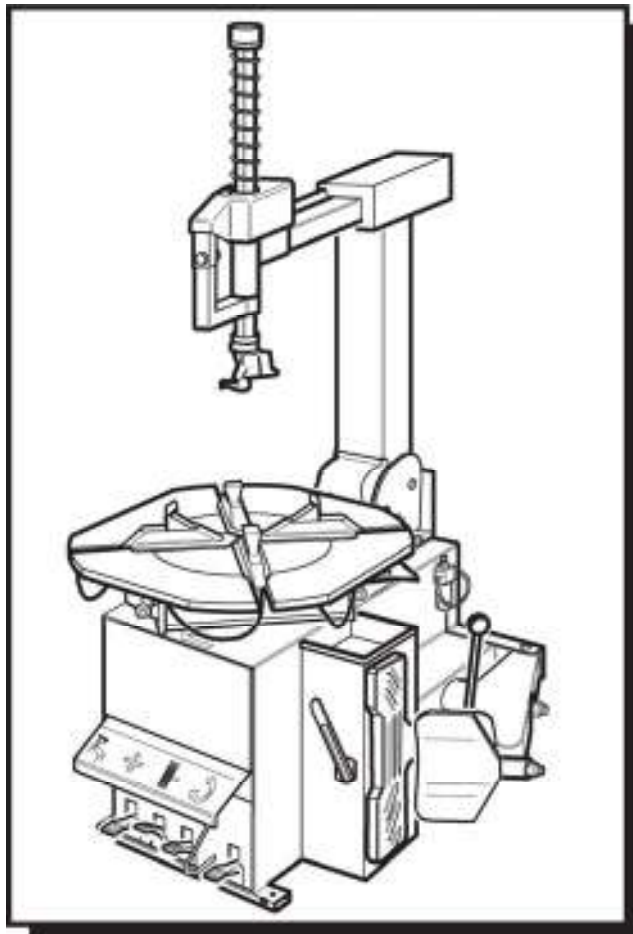

USE AND MAINTENANCE MANUAL



AUTOMATIC CAR TIRE CHANGER

X 203



PRINTING CHARACTERS AND SYMBOLS

Throughout this manual, the following symbols and printing characters are used to facilitate reading:

	Indicates the operations which need proper care
	Indicates prohibition
	Indicates a possibility of danger for the operators
BOLD TYPE	Important information

	WARNING: before operating the lift and carrying out any adjustment, read carefully chapter 7 “installation” where all proper operations for a better functioning of the lift are shown.
---	--

CONTENTS

1	INTRODUCTION	4
2	GENERAL INFORMATION	6
3	TRANSPORT, UNPACKING AND STORAGE	9
4	INSTALLATION	10
5	OPERATION	16
6	INFLATING	20
7	MAINTENANCE	22
8	TROUBLESHOOTING	24
9	ELECTRIC AND PNEUMATIC DIAGRAM	25

CHAPTER 1 – INTRODUCTION

1.1 INTRODUCTION

Thank you for purchasing a product from the line of Automatic tire changers. The machine has been manufactured in accordance with the very best quality principles. Follow the simple instructions provided in this manual to ensure the correct operation and long life of the machine. Read the entire manual thoroughly and make sure you understand it.

1.2 TYRE CHANGER IDENTIFICATION DATA

A complete description of the “Tire Changer Model” and the “Serial number” will make it easier for our technical assistance to provide service and will facilitate delivery of any required spare parts. For clarity and convenience, we have inserted the data of your tire changer in the box below. If there is any discrepancy between the data provided in this manual and that shown on the plate fixed to the tire changer, the latter should be taken as correct.

LOGO		
Type:		
Volt	Amp	Kw
Ph	Hz	
Year of manufacturing:		
Air supply: 8-10 bar (115 – 145 PSI)		

1.3 MANUAL KEEPING

For a proper use of this manual, the following is recommended:

- Keep the manual near the lift, in an easily accessible place.
- Keep the manual in an area protected from the damp.
- Use this manual properly without damaging it.
- Any use of the machine made by operators who are not familiar with the instructions and procedures contained herein shall be forbidden.

This manual is an integral part of the manual: it shall be given to the new owner if and when the machine is resold.

	The illustrations have been made out of prototypes pictures. It is therefore possible that some parts or components of standard production differ from those represented in the pictures.
---	--

1.4 GENERAL SAFETY PRECAUTIONS

	The tire changer may only be used by specially trained and authorized expert personnel.
---	--

- Any tampering or modification to the equipment carried out without the manufacturer's prior authorization will free him from all responsibility for damage caused directly or indirectly by the above actions.
- Removing or tampering with safety devices immediately invalidates the guarantee.
- The tire changer comes complete with instruction and warning transfers which are designed to be long-lasting. If they should for any reason be damaged or destroyed, please ask immediately for replacements from the manufacturer.

TO THE READER

Every effort has been made to ensure that the information contained in this manual is correct, complete and up-to date. The manufacturer is not liable for any mistakes made when drawing up this manual and reserves the right to make any changes due the development of the product, at any time

CHAPTER 2 – GENERAL INFORMATION

2.1 INTENDED USE

- This automatic tire changer has been designed and manufactured exclusively for removing and mounting tires from/onto rims from 10" to 24" and a maximum diameter of 1000 mm.
- In particular **THE MANUFACTURER** cannot be held responsible for any damage caused through the use of this tire changer for purposes other than those specified in this manual, and therefore inappropriate, incorrect and unreasonable.

2.2 DESCRIPTION

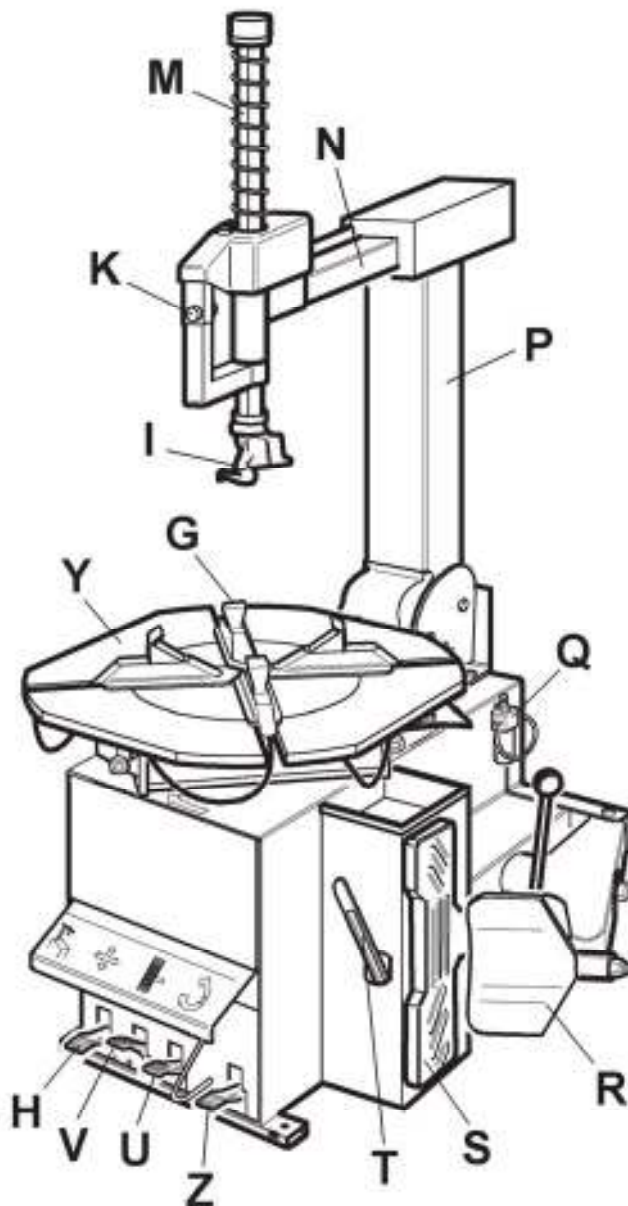

- G) Clamps
- I) Mounting head
- L) Airline Gauge
- M) Mounting bar
- N) Horizontal arm
- P) Vertical arm
- Q) Air supply
- R) Bead breaker
- S) Wheel support
- T) Bead lifting lever
- U) Clamp control pedal
- V) Clamp control pedal
- Z) Reverser control pedal
- H) Tilting arm pedal
- Y) Turntable
- K) Locking button

Fig . 1

2.3 DANGER WARNING SIGNS

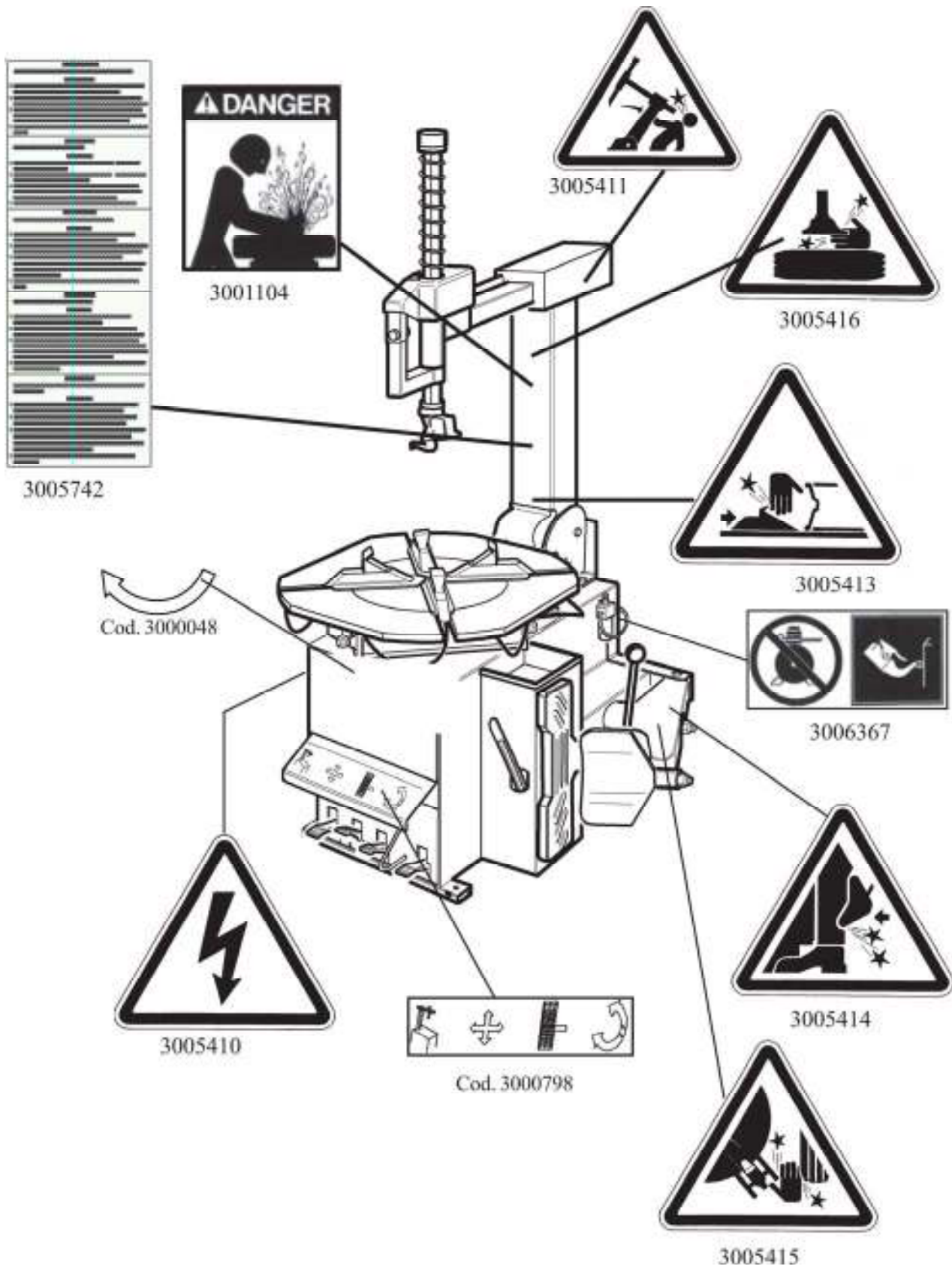

Fig. 2

2.4 TECHNICAL SPECIFICATION

External locking rim dimension	10" – 20"
	11" – 21"
	12" – 22"
Internal locking rim dimension	12"- 22"
	13" – 23"
	14" – 24"
Max. tire diameter	1000mm (39")
Max tire width	330mm (13")
Force on bead breaker blade (10 bar)	2500 kg
Working pressure	10 bar (145 psi)
Inflating pressure device max.	3.5 bar (50 psi)
Power supply voltage	220V/380V 230V/400V 3 Ph
	110V 220V 230V 1Ph
Motor power	0.55 (3 ph single speed)
	0.8/1.1 kw (3ph double speed)
	0.75 kw (1ph)
Rotating speed	7 – 14 rpm
Max spindle torch	1200 NM
Dimension	975 x 760 x 950
Net weight	229 kg STND
	251 kg GT
Noise level in working condition	< 70 dB (A)

CHAPTER 3 – TRANSPORTATION, UNPACKING AND STORAGE

3.1 TRANSPORTATION

- The tire changer must be transported in its original packaging and kept in the position shown on the package itself.
- The packaged machine may be moved by means of a fork lift truck of suitable capacity. Insert the forks at the points shown in figure 3.

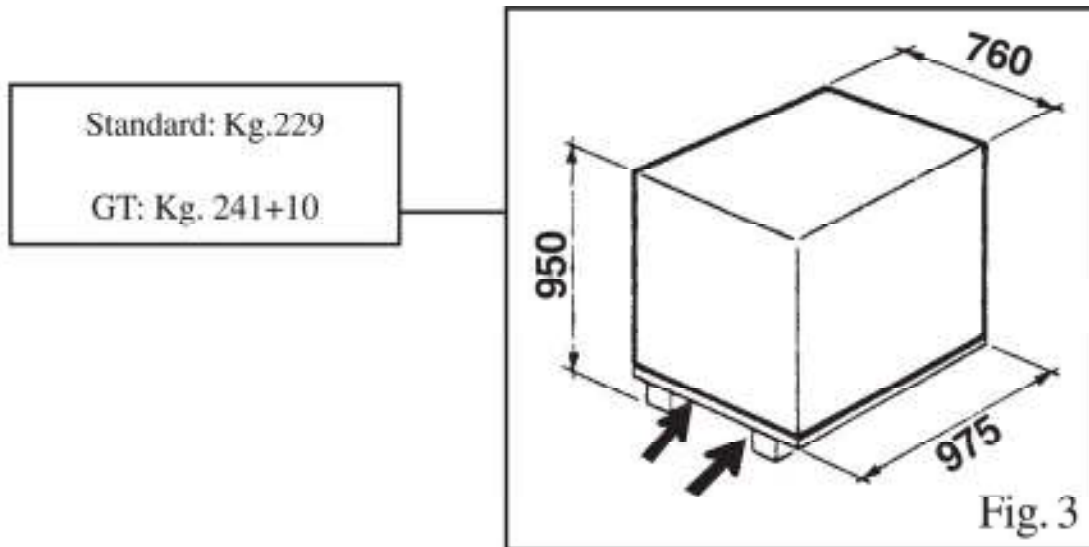

3.2 UNPACKING

- Remove the protective cardboard and the nylon bag.
- Check that the equipment is in perfect condition, making sure that no parts are damaged or missing. Use fig. 1 for reference.

	If in doubt do not use the machine and contact your retailer.
---	--

3.3 STORAGE

In the event of storage for long periods of time, be sure to disconnect all sources of power and grease the clamp sliding guides on the turntable to prevent them from oxidizing.

CHAPTER 4 – INSTALLATION

4.1 SPACE REQUIRED



When choosing the place of installation be sure that it complies with current safety at work regulations.

- The tire changer must be connected to the main electric power supply and the compressed air system. It is therefore advisable to install the machine near these power sources.
- The place of installation must also provide at least the space shown in pictures 4 - 4/A so as to allow all parts of the machine to operate correctly and without any restriction.
- If the machine is installed outside it must be protected by a lean-to.



The tire changer with electric motor cannot be used in explosive atmospheres, unless it is a proper version.

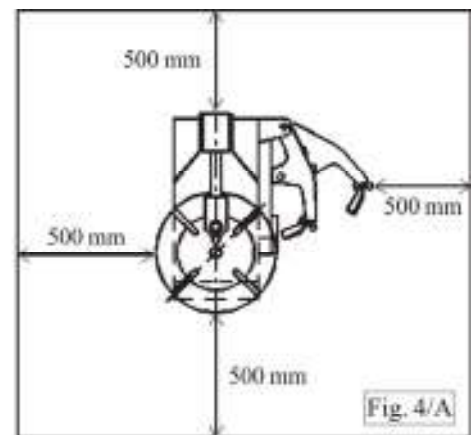
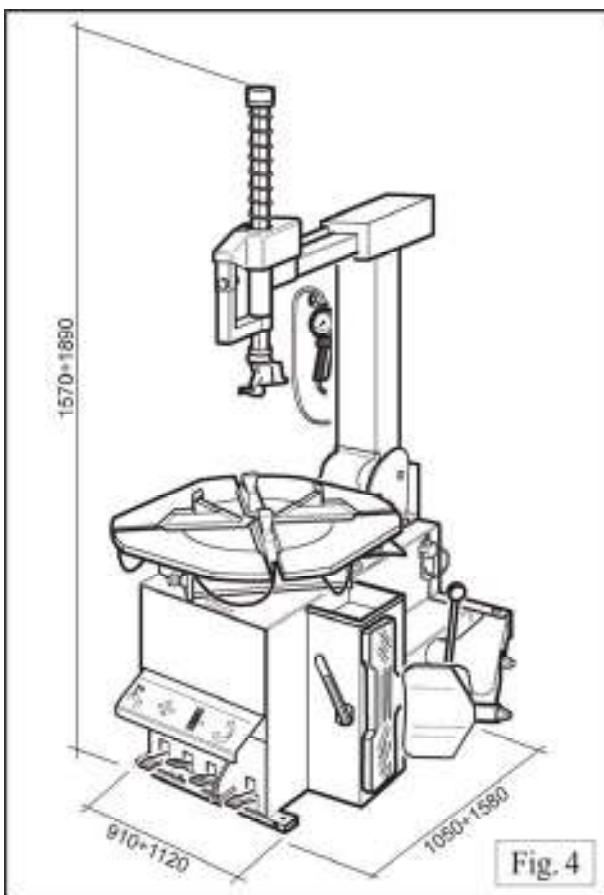

4.2 PARTS ASSEMBLY

4.2.1 Arm assembly

- Set the vertical arm into its housing on the machine body, as shown in Fig. 5.
- Set the rear articulation pin (1) and the washers (2) and tighten the screws (4). Fig. 6.
- Set the pin (5) and washer (6) to joint the tilting cylinder to the arm as show in the Fig. 7.
- Tighten the nut (7). Enable the cylinder to operate correctly so the tilting arm without frictions, pay attention not to tighten it too much.
- Tighten the screw (8) as shown in Fig. 8.
- Fix the inflating gauge hook (9) on the vertical arm.
- Tighten the screw and washer (10) to fix the plastic cover as shown in Fig. 9.
- Fix the wheel rubber support (S) by means of washers (12) and screws (13) as shown in Fig. 9/A

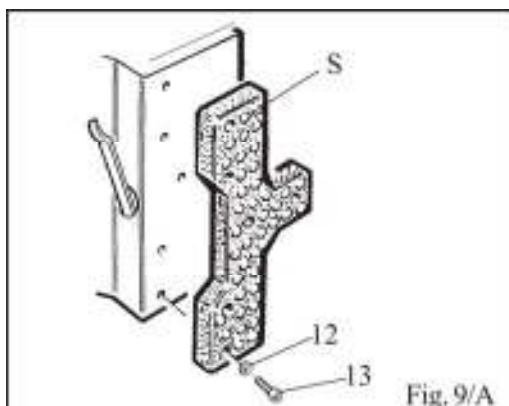
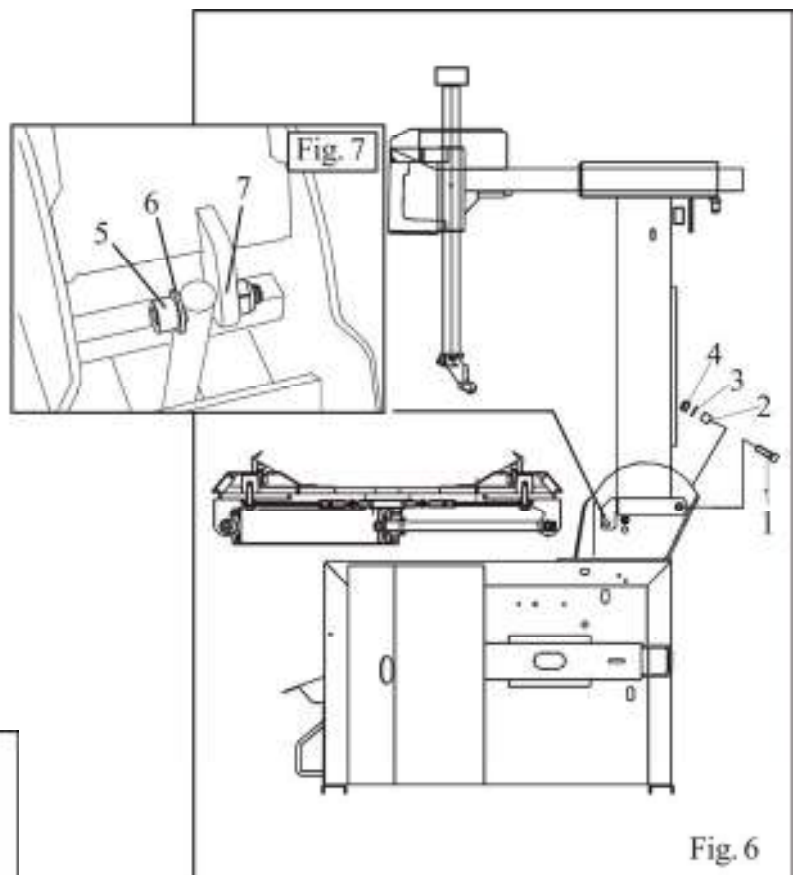
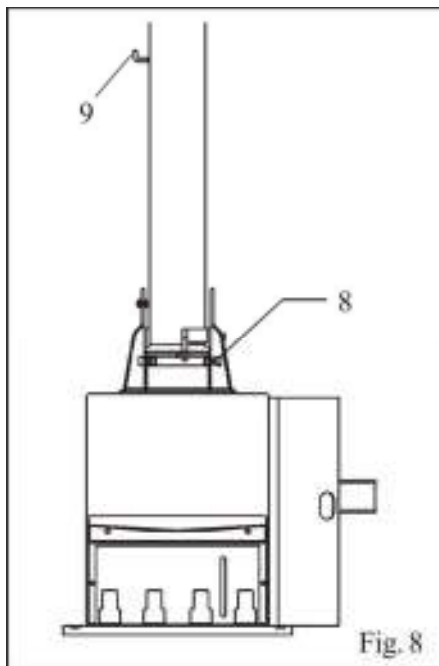
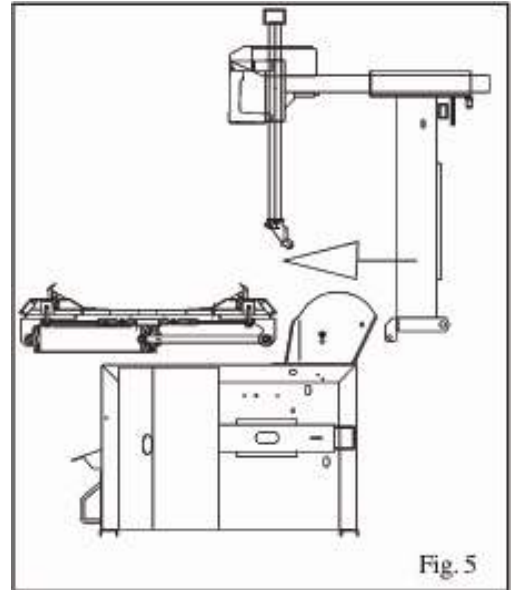

- Connect the machine to the air network (Fig. 9/b)
- Press the bead breaker's pedal to release the hook from the cylinder's shaft (Fig. 9/c)
- Mount the bead breaker arm as shown in Fig. 9/d:
 - Set the arm "a" into the proper seat, set the screw into the hole and screw the nut WITHOUT TIGHTENING.
 - Set the pivot pin "b" into the hole on the arm and let the cylinder's shaft pass through the pin's hole. Screw two nuts WITHOUT TIGHTENING.
 - Set the spring by hooking it at the indicated points.
- Screw the bead breaker arm's screw as indicated in Fig 9/e
- Screw the nut as indicated in Fig 9/f

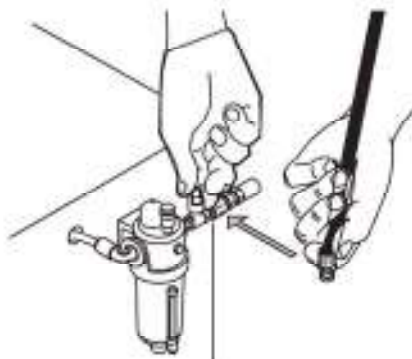

Fig. 9/b - Abb. 9/b

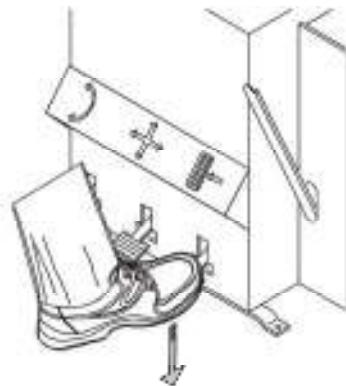

Fig. 9/c - Abb. 9/c

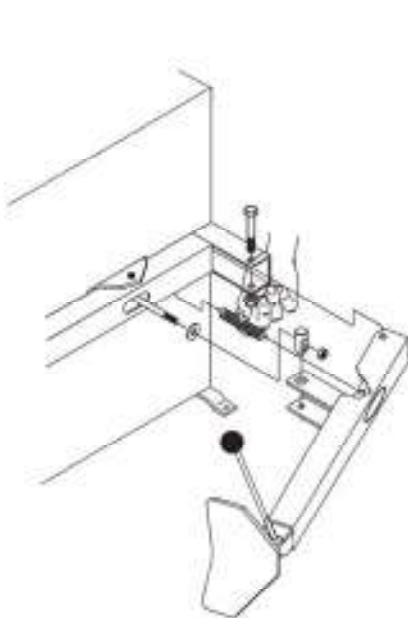
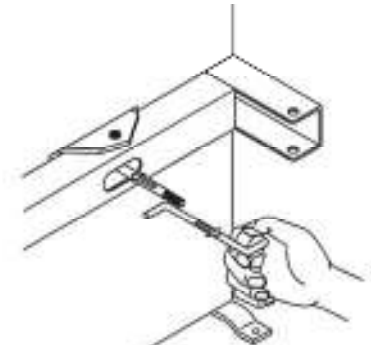

Fig. 9/d - Abb. 9/d

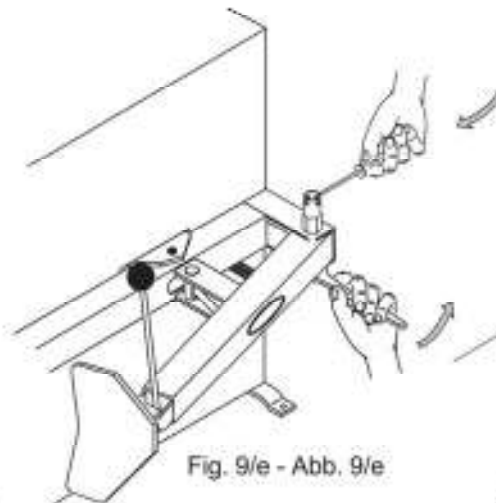

Fig. 9/e - Abb. 9/e

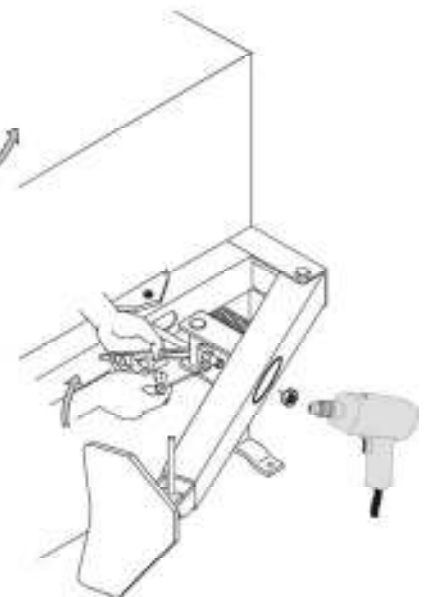
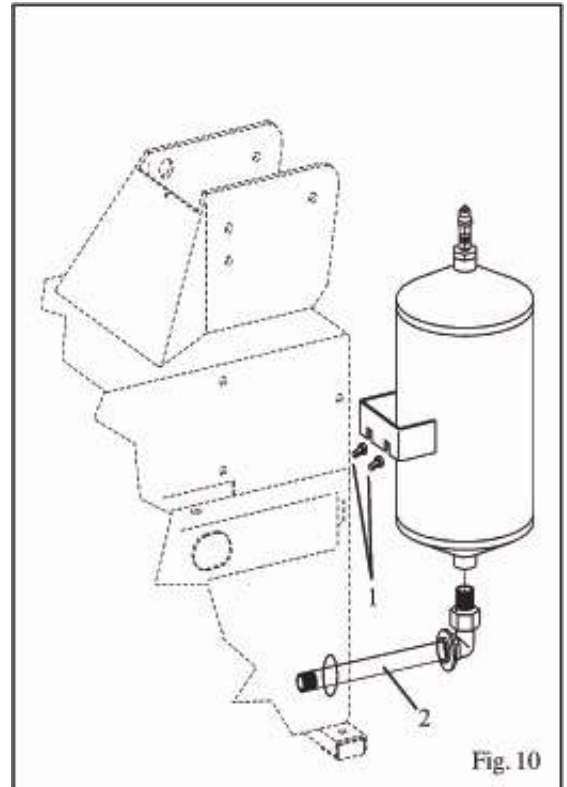

Fig. 9/f - Abb. 9/f

4.2.2 Mounting and connecting the GT tank (optional)

- Fix the tank on the back side of the machine body through the proper screw. Fig. 10.
- Demount the side panel.
- Route the hose (2), situated inside the machine body, through the hole on the back side of the body.
- Tighten the hose (2) to the tank through the proper union.



4.2.3 Mounting and connecting the manometer (optional)

- Fix the manometer to the vertical arm through the proper screw. Fig. 11.
- Route the connecting spiral hose through the small hole on the back side of the machine body.
- Connect the rilsan hose to the union of the pressure limiting device, situated on the inflating pedal.

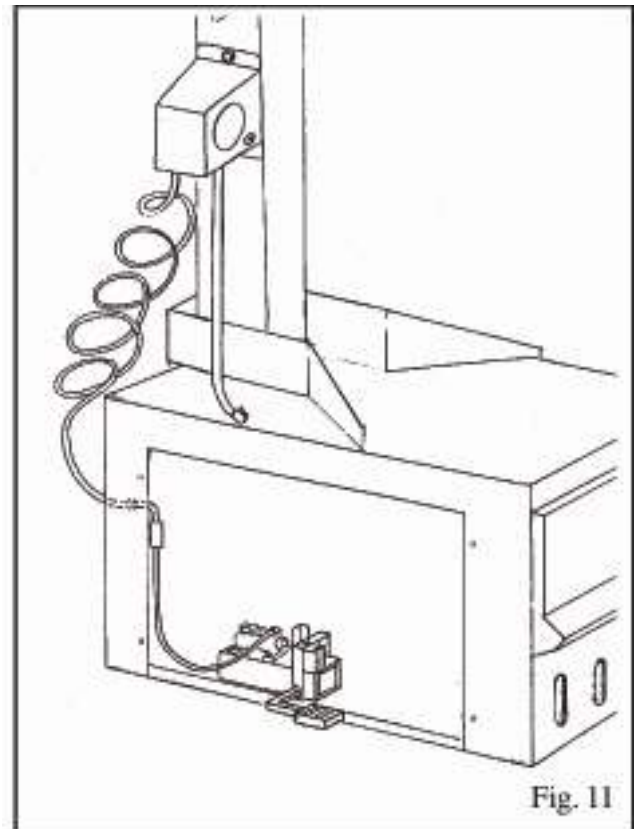

4.3 COMMISSIONING

	<p>Any electric connection job must be carried out by professionally qualified personnel.</p> <p>Make sure that the power supply is right.</p> <p>Make sure the connection of the phases is right. Improper electrical hook-up can damage motor and will not be covered under warranty.</p>
---	--

- Check to make sure the characteristics of your systems correspond to those required by the machine. If you have to change the machine's operating voltage, make the necessary adjustments to the terminal board referring to the electric diagram in chapter 9.
- Connect the machine to the compressed air system by means of the air connection (Q) that protrudes from the rear section.

	<p>Connect the machine to the electric network, which must be provided with line fuses, a good earth plate in compliance with regulations in force and it must be connected to an automatic circuit breaker (differential) set at 30 mA.</p> <p>Should the tire-changer be lacking in electric plug, the user must set one, which is at least 16 A and which conforms to the voltage of the machine, in compliance with the regulations in force.</p>
---	---

4.4 OPERATING TESTS

- When pedal (Z) is pressed down the turntable (Y) should turn in a clockwise direction. When pedal is pulled up the turntable should turn in an anticlockwise direction.

	<p>If the turntable turns in the opposite direction to that shown, reverse two of the wires in the three-phase plug.</p>
---	---

- Pressing the pedal (U) activates the bead breaker (R); when the pedal is released the bead breaker returns to its original position.
- Pressing the pedal (V) opens the four clamps (G); when the pedal is pressed again they close.
- Pressing the pedal (H) tilts the arm (P); when the pedal is pressed again it returns to its working position.
- Position 1 of the locking button (K) locks the mounting bar (N) and the horizontal arm (M).
- Position 2 of the locking button (K) unlocks the arms.
- Pressing the trigger on the airline gauge cause air to be released from the head.

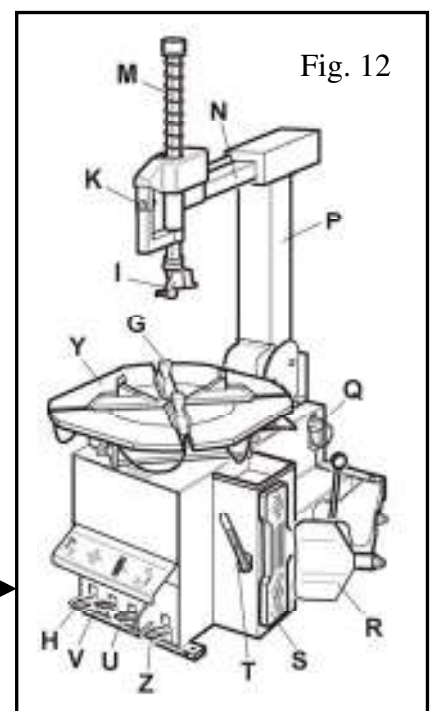
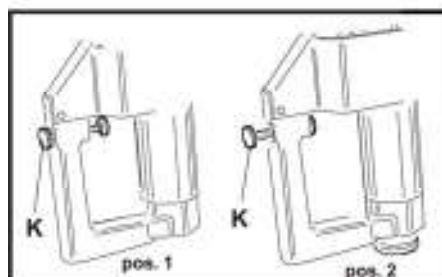

4.4.1 GT version (optional)

	<p>Do NOT LEAN on the turntable during this operation. Possibly dirty dust on turntable could offend the operator's eyes. For the same reason, be carefully as not to accidentally push the inflating pedal while working.</p>
---	---

- When the pedal located on the left side of the machine body is pushed down to its intermediate position (B), air is released from the airline gauge.
- When the pedal (C) is pushed down completely, air is released from the airline gauge with a powerful jet from the nozzles located on the turntable clamps.

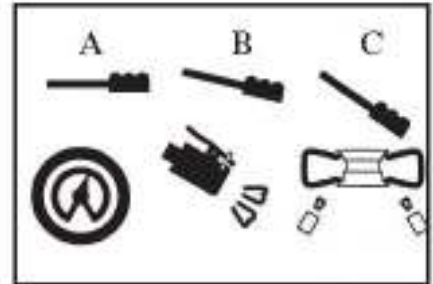

Fig. 13

4.5 TURNTABLE LOCKING VALUE ADJUSTING

The tire changer turntable is preset by the manufacturer on a middle range measure from 11" to 21" **ext.** (considering the rim outer side and) from 13" – 23" **int.** (if you lock the rim from inner side). It is however possible to change this dimension range in case of need when working on larger or small rims; it is enough to change the position of the 4 clamps are shown in the figures below. The obtainable value starts from a minimum of 10"-20" ext. and 12"-22" int. until a maximum of 12"-22" ext. and 14"-24" int.

To change the position, proceed as follows:

- Unscrew screw (1) by means of the Allen wrench.
- Remove the locking clamp (2) and the slide piece (3).
- Align the slide hole with one of the guide holes (4) according to the locking dimensions you want to set. Use the measures below for reference.

	<p>It is important to perform the above mentioned operation for all the 4 clamps to avoid any unbalance in locking phase.</p>
---	--

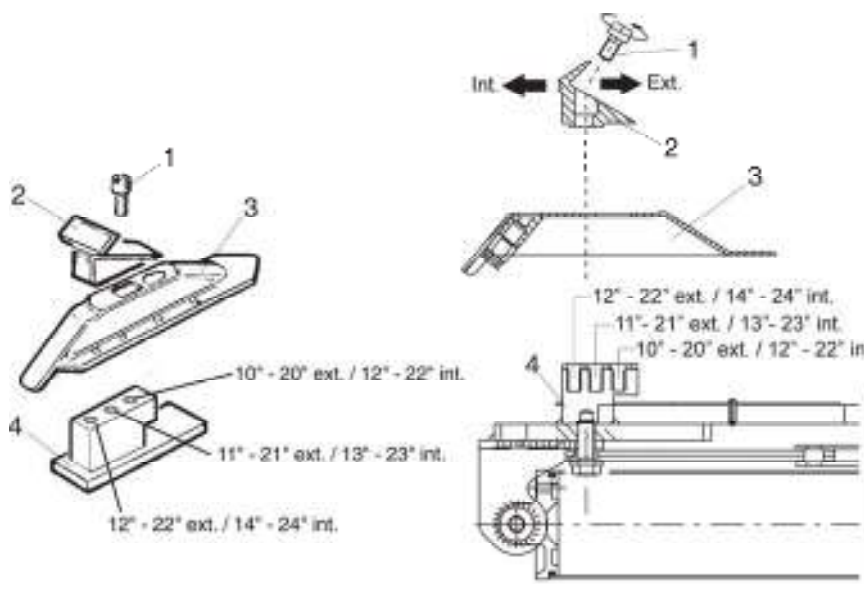

CHAPTER 5 – OPERATION



Do not use the machine until you have read and understood the entire manual and the warning provided.

Before carrying out any operation, deflate the tire and take off all the wheel balancing weights.

The operation of the tire changer is divided into three parts:

- a) BREAKING THE BEAD b) REMOVING THE TIRE c) MOUNTING THE TIRE



It is advised to equip the tire changer with the pressure regulator.

5.1 BREAKING THE BEAD



Bead breaking must be done with the utmost care and attention. When the bead breaker pedal is operated the bead breaker arm moves quickly and powerfully. Anything within its arrange of action can be in danger of being crushed.

- Check that the tire is deflated. If not, deflate it.
- Close the turntable clamps completely.



Bead breaking with the clamps in open position can be extremely dangerous for operator's hands.

During bead breaking operations NEVER touch the side of the tire.

- Position the wheel against the rubber stops on the right side of the tire changer (S).
- Position the bead breaker (R) against the tire bead at a distance of about 1 cm from the rim (fig. 15). Pay attention to the blade, which must operate correctly onto the tire and not onto the rim.
- Press down the pedal (U) to activate the bead breaker and release it when the blade has reached the end of its travel or in any case when the bead is broken.
- Rotate the tire slightly and repeat the operation around the entire circumference if the rim and from both sides until the bead is completely detached from the rim.

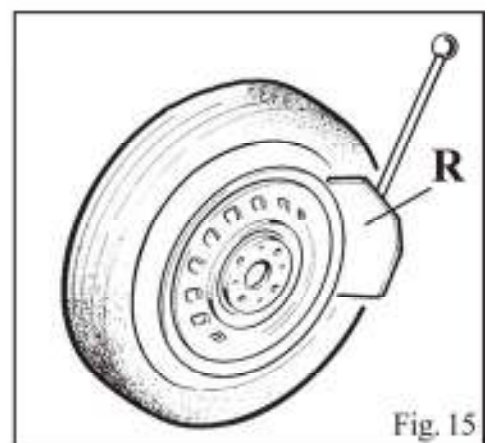
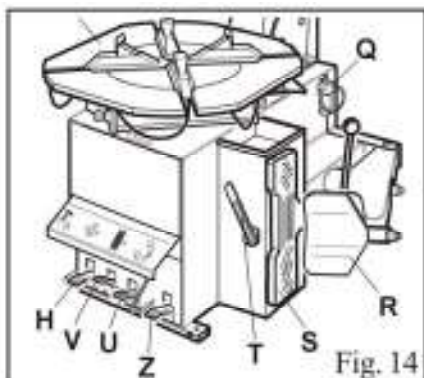

5.2 REMOVING THE TIRE



Before any operation make sure to remove the old wheel balancing weights and check that the tire is deflated.



During arm tilting make sure that nobody stands behind the tire changer.

- Press pedal (H) to tilt the arm (P) thereby clearing the turntable.
- Spread the supplied grease (or grease of a similar type) onto the tire bead.



Failure to use the grease could cause serious damage to the tire bead.



During rim locking MEVER keep your hands under the tire. For a correct locking operation set the tire exactly in the middle of turntable.

OUTER LOCKING

- Position the clamps (G) according to the reference mark on the turntable (Y) by pressing pedal (V) down to its intermediate position.
- Place the tire on the clamps and keeping the rim pressed down, press the pedal (V) as far as it will go.

INNER LOCKING

- Position the clamps (G) so that they are completely closed.
- Place the tire on the clamps and press the pedal (V) to open the clamps and thereby lock the rim.



Make sure that the rim is firmly fixed to the clamps.



Never keep your hands onto the wheel: the arm recovery to “working position” could set the operator at risk of hand crushing between rim and mounting head.

- Return the arm (P) by pressing the pedal (H).
- Unlocking the mounting bar (M) by placing the locking button (K) in the position “2”.
- Lower the mounting bar (M) so that the mounting head (I) rests on the upper edge of the wheel rim and lock the entire assembly by placing the locking button in the position “1” This will lock the arm in both vertical and horizontal direction and automatically move the mounting head (I) of about 2 mm from the rim.
- With the lever (T) inserted between the bead and the front section of the mounting head (I), move the tire bead over the mounting head.



In order to avoid damaging the inner tube if there is one, it is advisable to carry out this operation with the valve about 10 cm right of the mounting head. (Fig. 16)



Chains, bracelets, loose clothing or foreign objects in the vicinity of the moving parts can represent a danger for the operator.

- With the lever held in this position, rotate the turntable (Y) in a clockwise direction by pressing pedal (Z) down until the tire is completely separated from the wheel rim (Fig. 17).
- In order to remove the inner tube if there is one, tilt the arm (P) by pushing the pedal (H) down directly without unlocking the mounting bar.
- Repeat the operation for the other bead.

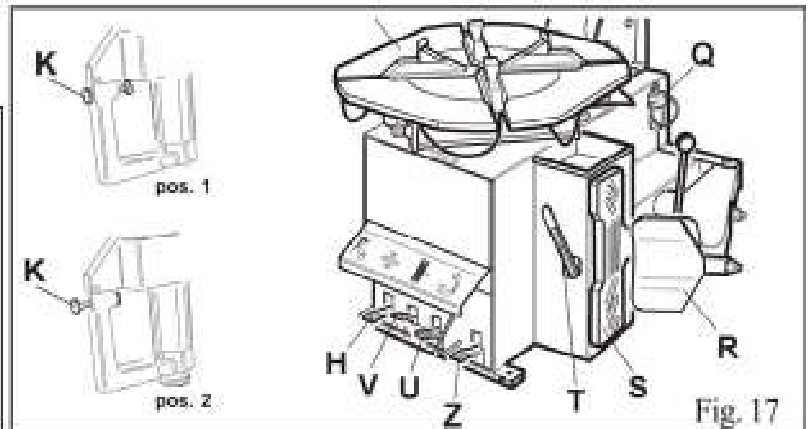
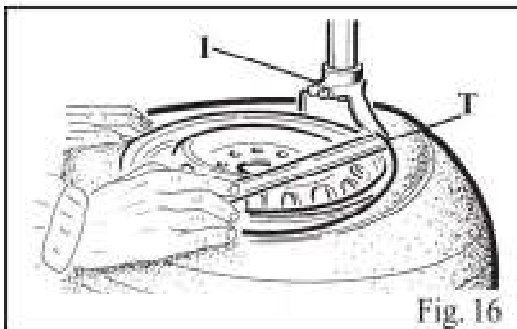

5.3 MOUNTING THE TIRE



It is utmost important to check the tire and rim to prevent tire explosion during the inflating operations. Before beginning mounting operation, make sure that:

The tire and cord fabric are not damaged. If you note defects DO NOT mount the tire.

The rim is without dents and is not warped. Pay attention to alloy rims, internal micro-cracks are not visible to naked eye. This can compromise the rim and can also be a source of danger especially during inflation.

The diameter of the rim and tire are exactly the same. NEVER try to mount a tire on a rim if you cannot identify the diameter of both.

- Lubricate the tire beads with the special grease in order to avoid damaging them and to facilitate the mounting operations.



During rim locking NEVER keep your hands under the tire. For a correct locking operation set the tire exactly in the middle of turntable.

- For 10 to 20 inch wheels lock the rim using the inner part of the clamps.
- For 12 to 22 inch wheels lock the rim using the outer part of the clamps.



During arm tilting make sure that nobody stands behind the tire changer.



When working with rims of the same size it is not necessary always to lock and unlock the mounting bar; you only need to tilt and return the ram (P) with the arm and the bar locked in their working positions.



Never keep your hands onto the wheel: the arm recovery to “working position” could set the operator at risk of hand crushing between rim and mounting head.

- Move the tire so that the bead passes below the front section of the mounting head and is brought up against the edge of the rear section of the mounting head itself.
- Keeping the tire bead pressed down into the wheel rim channel with your hands, press down on the pedal (Z) to rotate the turntable clockwise. Continue until you have covered the entire circumference of the wheel rim (Fig. 19).



To prevent industrial accidents, keep hands and other parts of the body as far as possible from the tool arm when the table top is turning.

- Insert the inner tube if there is one and repeat the same operations to mount the upper side of the tire.



Demounting and mounting are always done with the clockwise turntable rotation. Anticlockwise rotation is used only to correct operator’s errors or if the turntable stalls.

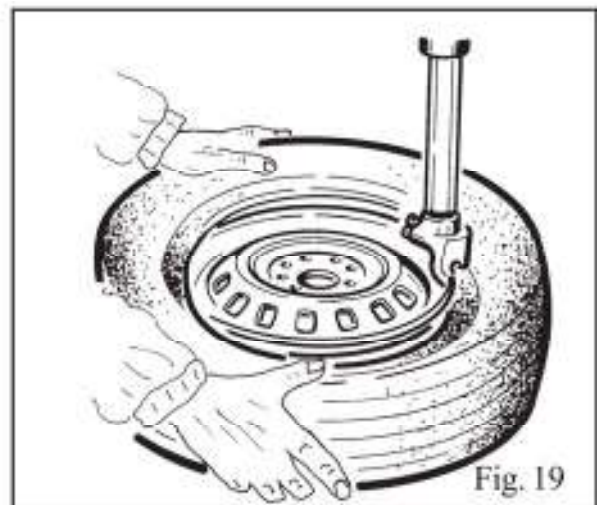
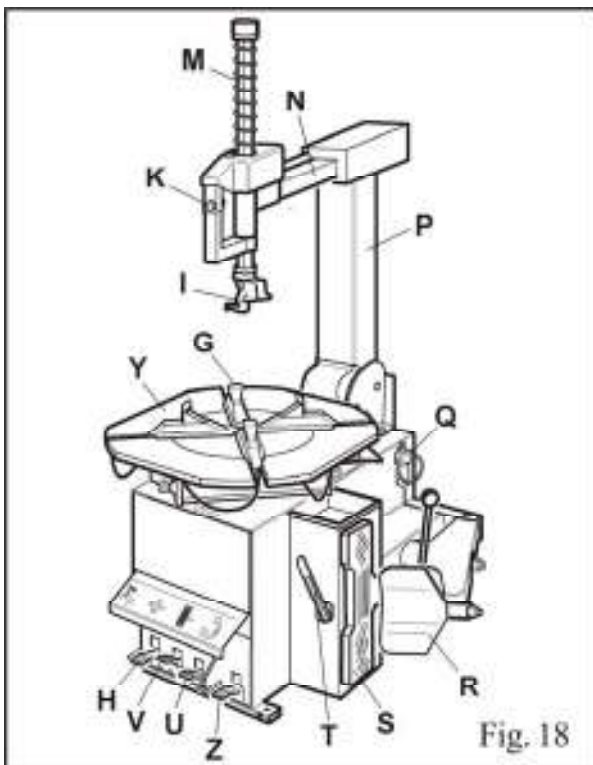

CHAPTER 6 – INFLATING



The greatest attention is called for when inflating the tires. Keep strictly to the following instructions since the tire changer is NOT designed and built to protect (or anyone else in the vicinity of the machine) if the tire bursts accidentally.

▲ DANGER



A bust tire can cause serious injury or even death of the operator.

Check carefully that the wheel rim and the tire are of the same size.

Check the state of wear of the tire and that it has no defects before beginning the inflation.

Inflate the tire with brief jets of air, checking the pressure after every jet.

All our tire changers are automatically limited to a maximum inflating pressure of 3.5 bar (51 psi). In any case NEVER EXCEED THE PRESSURE RECOMMENDED BY THE MANUFACTURER.

Keep your hands and body as far away as possible from the tire.

6.1 INFLATING TIRE USING AIRLINE GAUGE

In the standard version our tire changer are supplied with an airline gauge. To inflate a tire proceed as follows:

- Connect the airline gauge to the tire valve.
- Make a last check to be certain that tire and rim diameter correspond.
- Check to be certain that rim and beads are sufficiently lubricated. If necessary lubricate some more.
- Seat the beads with short jets of air. Between air jets, check the air pressure on the inflator gauge.
- Continue to inflate the tire with short jets of air and constantly checking the pressure between until the required pressure has been reached.

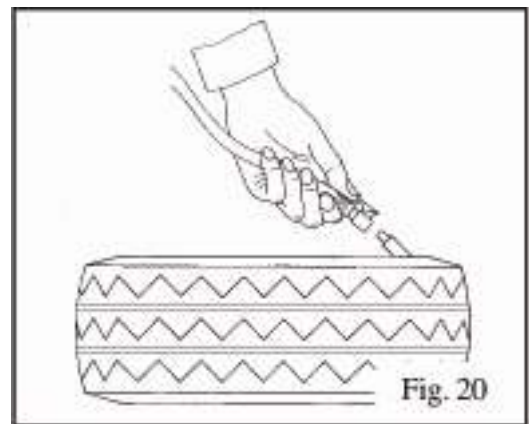

▲ DANGER



EXPLOSION HAZARD!

Never exceed 3.5 bar (51 psi) when seating beads or inflating tires.

If a higher inflating pressure is required remove the wheel from turntable and continue the inflating procedure inside a special protection cage (commercially available).

Never exceed the max. inflating pressure given by the tire manufacturer.

ALWAYS keep hands and body back from inflating tire.

ONLY special trained personnel are allowed to perform these operations. Do not allow other persons to operate or to stay near the tire changer.

6.2 INFLATING TIRES WITH GT SYSTEM (OPTIONAL)

The GT inflating system facilitates inflation of tubeless tires to a powerful jet of air from the nozzle positioned on the clamps.



During this phase of work the level of noise can reach 85db (A). It is advisable to use a noise protection.

- Lock the wheel on the turntable and connect the inflating head to the tire valve.
- Make a last check to be certain that tire and rim diameter correspond.
- Check to be certain that rim and beads are sufficiently lubricated. If necessary lubricate some more.
- Press the pedal down to intermediate position (B – Fig. 21)
- If the bead of tire is not well seated, due to a strong bead, lift tire manually until the upper bead seats against the rim, then press pedal all the way down (C-Fig. 21). A strong jet will be released through the nozzles in the slides and this will help the bead seal.
- Release the tires; set the pedal in the intermediate position (B – Fig. 21) and continue to inflate the tire with short jets of air and constantly checking the pressure between air jets until the required pressure has been reached.

▲ DANGER



EXPLOSION HAZARD!

Never exceed 3.5 bar (51 psi) when seating beads or inflating tires.

If a higher inflating pressure is required remove the wheel from turntable and continue the inflating procedure inside a special protection cage (commercially available).

Never exceed the max. inflating pressure given by the tire manufacturer.

ALWAYS keep hands and body back from inflating tire.

ONLY special trained personnel are allowed to perform these operations. Do not allow other persons to operate or to stay near the tire changer.

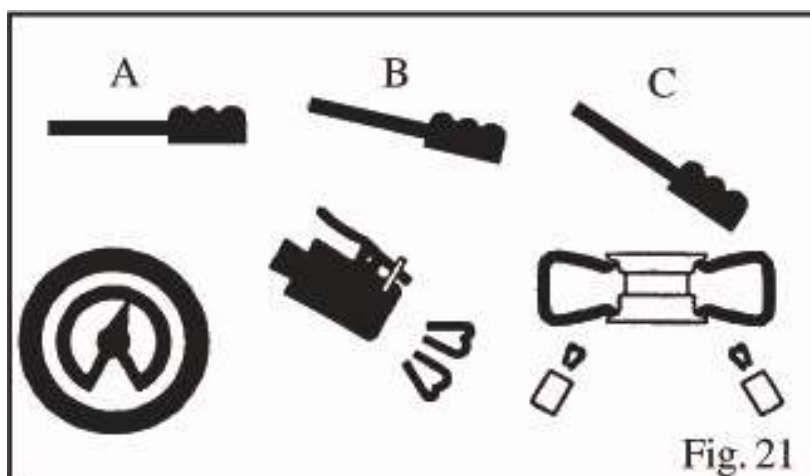

CHAPTER 7 – MAINTENANCE

7.1 GENERAL WARNINGS



Unauthorized personnel may not carry out maintenance work.

- Regular maintenance as described in the manual is essential for correct operation and long lifetime of the tire changer.
- If maintenance is not carried out regularly, the operation and reliability of the machine may be compromised, thus placing the operator and anyone else in the vicinity at risk.



Before carrying out any maintenance work, disconnect the electric and pneumatic supplies. Moreover, it is necessary to break the bead without load 3-4 times in order to let the air in pressure go out of the circuit.

- Defective parts must be replaced exclusively by expert personnel using the manufacturer's parts.
- Removing or tampering with safety devices (pressure limiting and regulating valves) is extremely forbidden.



In particular the Manufacturer shall not be held responsible for complaints deriving from the use of spare parts made by other manufacturers or for damage caused by tampering or removal of safety systems.

7.2 MAINTENANCE OPERATIONS

- Clean the turntable once a week with diesel fuel so as to prevent the formation of dirt, and grease the clamp sliding guides.
- Carry out the following operations at least every 30 days:
 - Check the oil level in the lubricator tank. If necessary, fill up by unscrewing the reservoir F. Only use ISO VG viscosity ISOHG class oil for compressed air circuit. (Fig. 22)
 - Check that a drop of oil is injected into the reservoir F very 3-4 times the pedal U is pressed down. If not, regulate using the screw D (fig. 22)
- After the first 20 days of work, retighten the clamp tightening screws on the turntable slides (Fig. 23).
- In the event of a loss of power, check that the drive belt is tight as follows.



Before any operation disconnect the electric power supplies.

- Remove the left side body panel of the tire changer by unscrewing the four fixing screws.
- Remove the drive belt by means of the special adjusting screw X on the motor support (Fig. 24).

- If necessary to adjust the vertical arm locking plate because the tool does not lock or it does not rise from the rim of 2mm necessary for working, adjust nuts as shown in Fig. 25.

For cleaning or replacing the silencer for opening/closing clamps, see Fig 26 and proceed as follows:

1. Remove the left side panel of the machine body by unscrewing the four fixing screws.
2. Unscrewing the silencer put on the pedal system, on the clamp opening/closing pedal.
3. Clean by a jet of compressed air or, if damaged, replace by referring to the spare parts catalogue.

For cleaning or replacing the silencer of bead breaker, see Fig. 27 and proceed as shown on previous point 1 and 3.

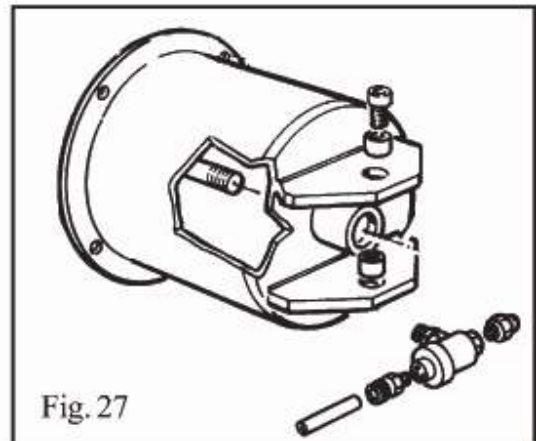
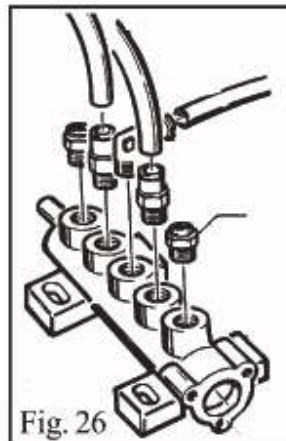
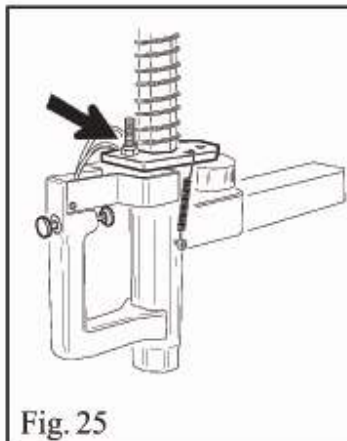
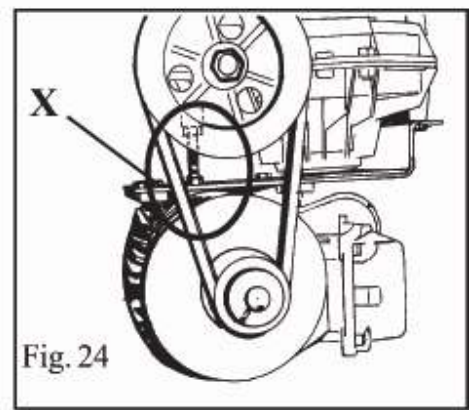
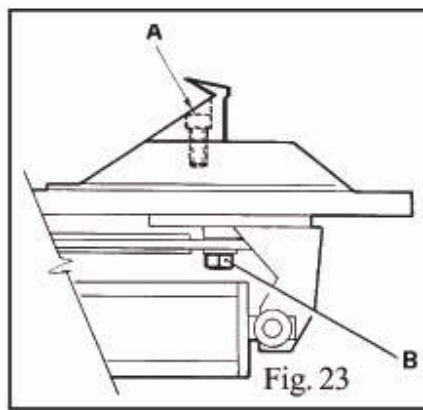
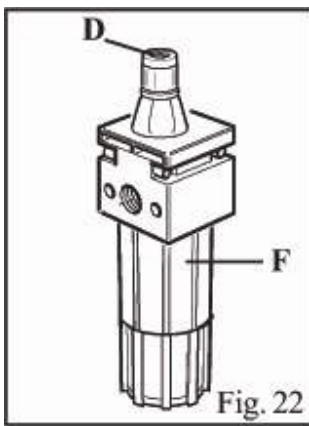

CHAPTER 8 – TROUBLE-SHOOTING

TROUBLE:	POSSIBLE CAUSE:	SOLUTION:
Turntable rotates only in one direction.	Reverser broken	Replace reverser
Turntable does not rotate.	Belt broken	Replace
	Reverser broken	Replace reverser
	Problem with motor	Check for loose wire in the motor, plug or socket. Replace motor
Turntable locks	Belt loose	Adjust the belt tension (chap. 7 Fig. 24)
Clamp slow to open or close	Silencer clogged	Clean or replace silencer
Turntable does not lock the wheel rim correctly	Clamps worn	Replace clamps
	Turntable cylinder(s) defective	Replace cylinder gasket
The tool touches the rim during the tire removing or mounting operations	Locking plate incorrectly adjusted or defective	Adjust or replace locking plate (chap 7 – Fig 25)
	Turntable locking screw loose	Tighten screw
Pedal lock out of working position	Return spring broken	Replace spring
Bead breaking operation difficult	Silencer clogged	Clean or replace silencer (chap 7 – Fig. 27)
	Bead breaker cylinder gasket broken	Replace gasket

CHAPTER 9 – ELECTRIC AND PNEUMATIC DIAGRAM

110V/220V/230V – 1PH

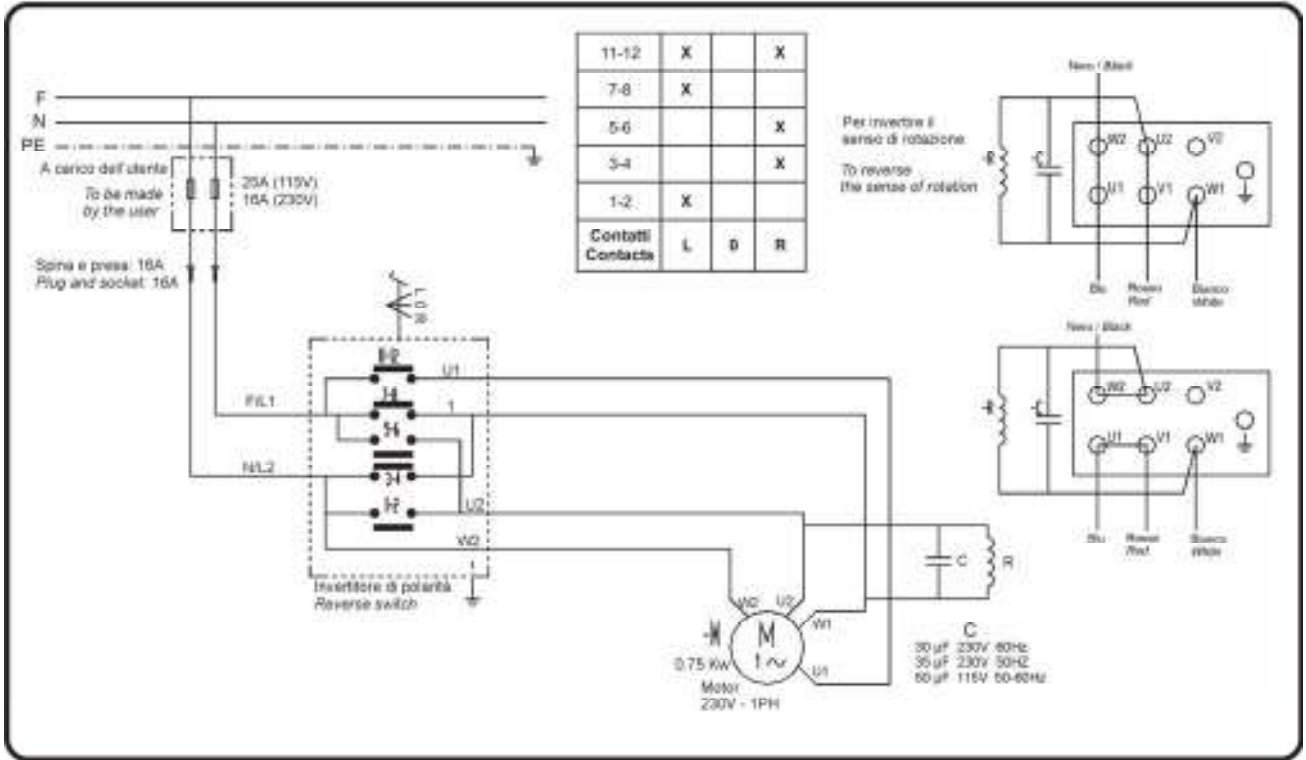

220V/230V/380V/400V – 3PH (SINGLE SPEED)

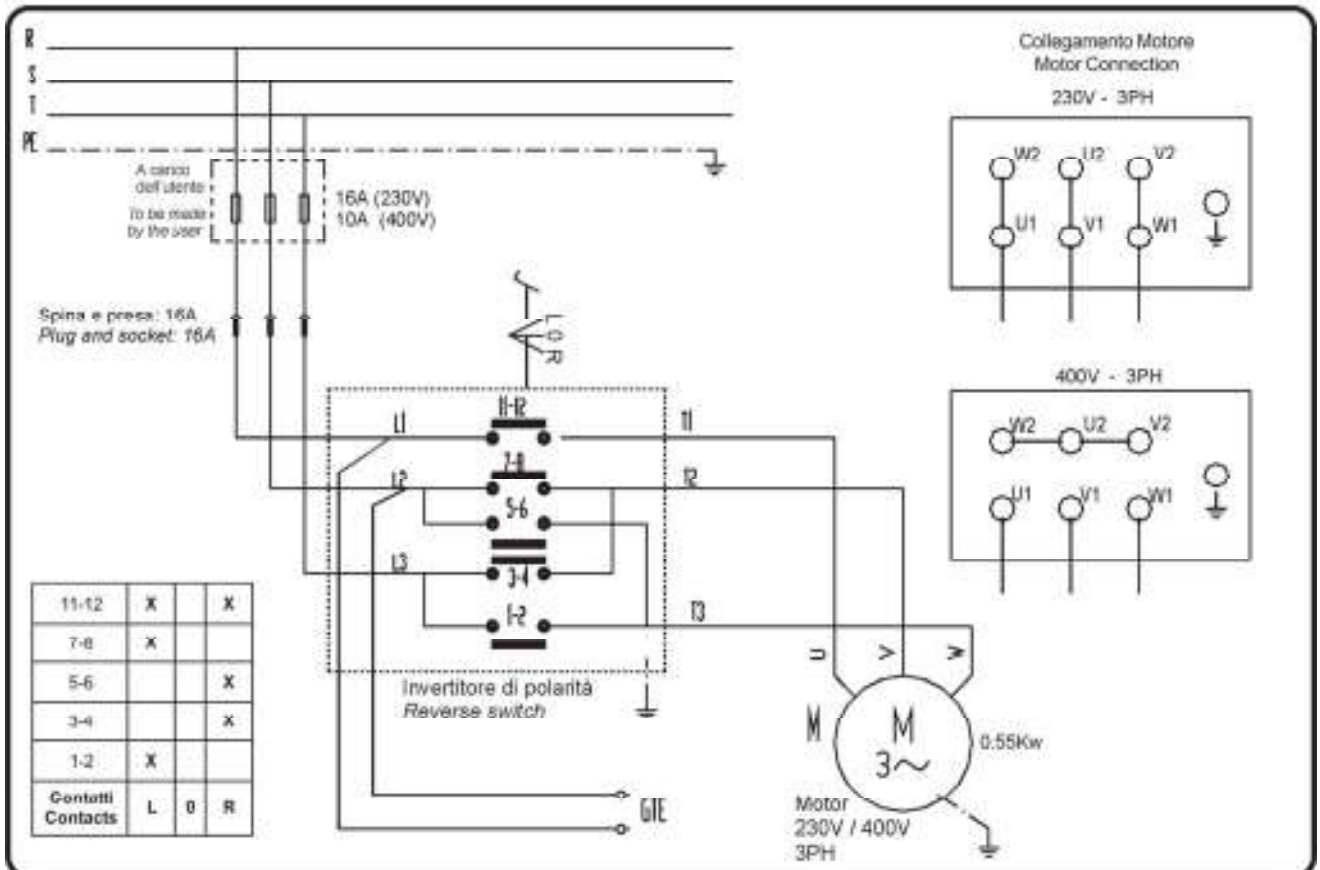

220V/230V/380V/400V – 3PH (DOUBLE SPEED)

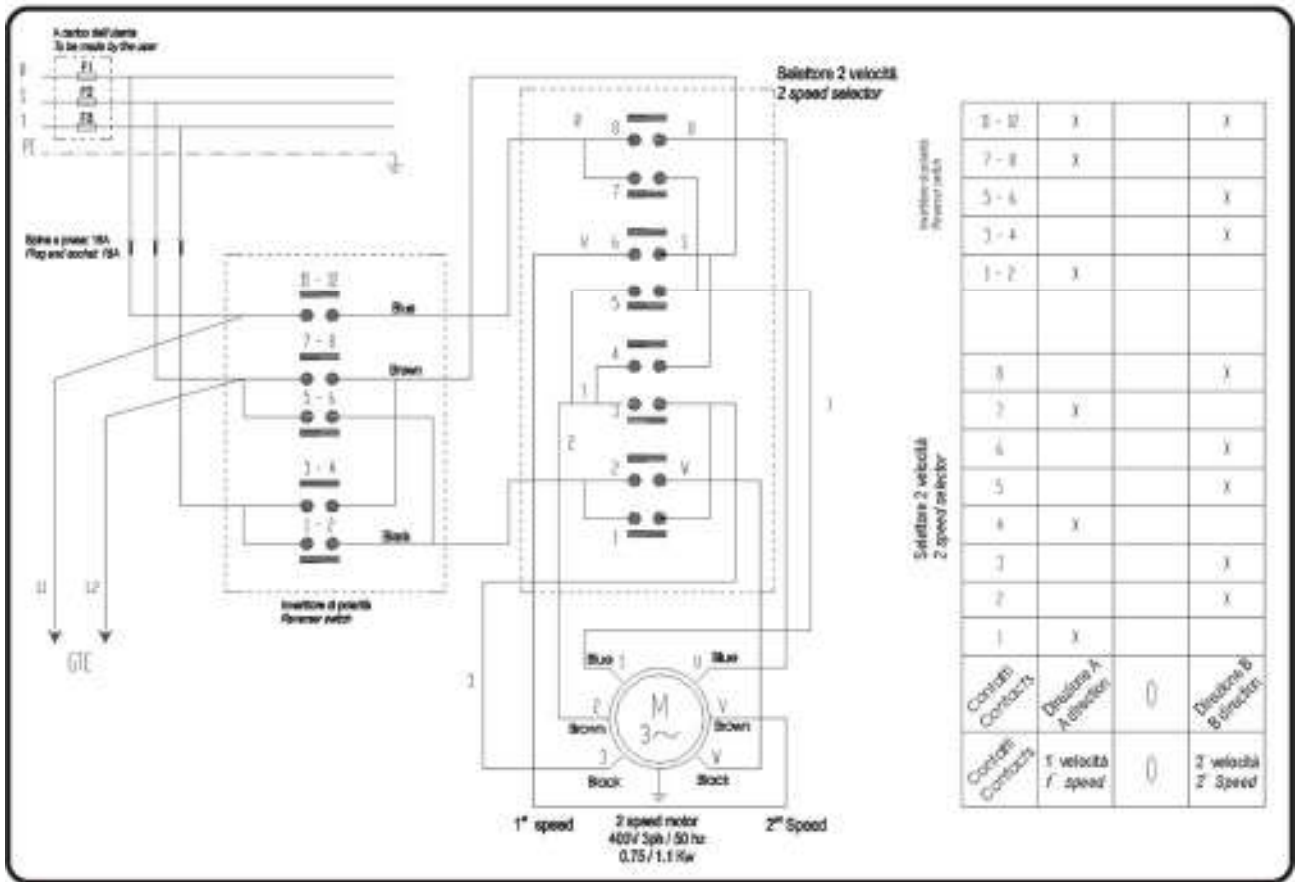

STANDARD PNEUMATIC SYSTEM DIAGRAM

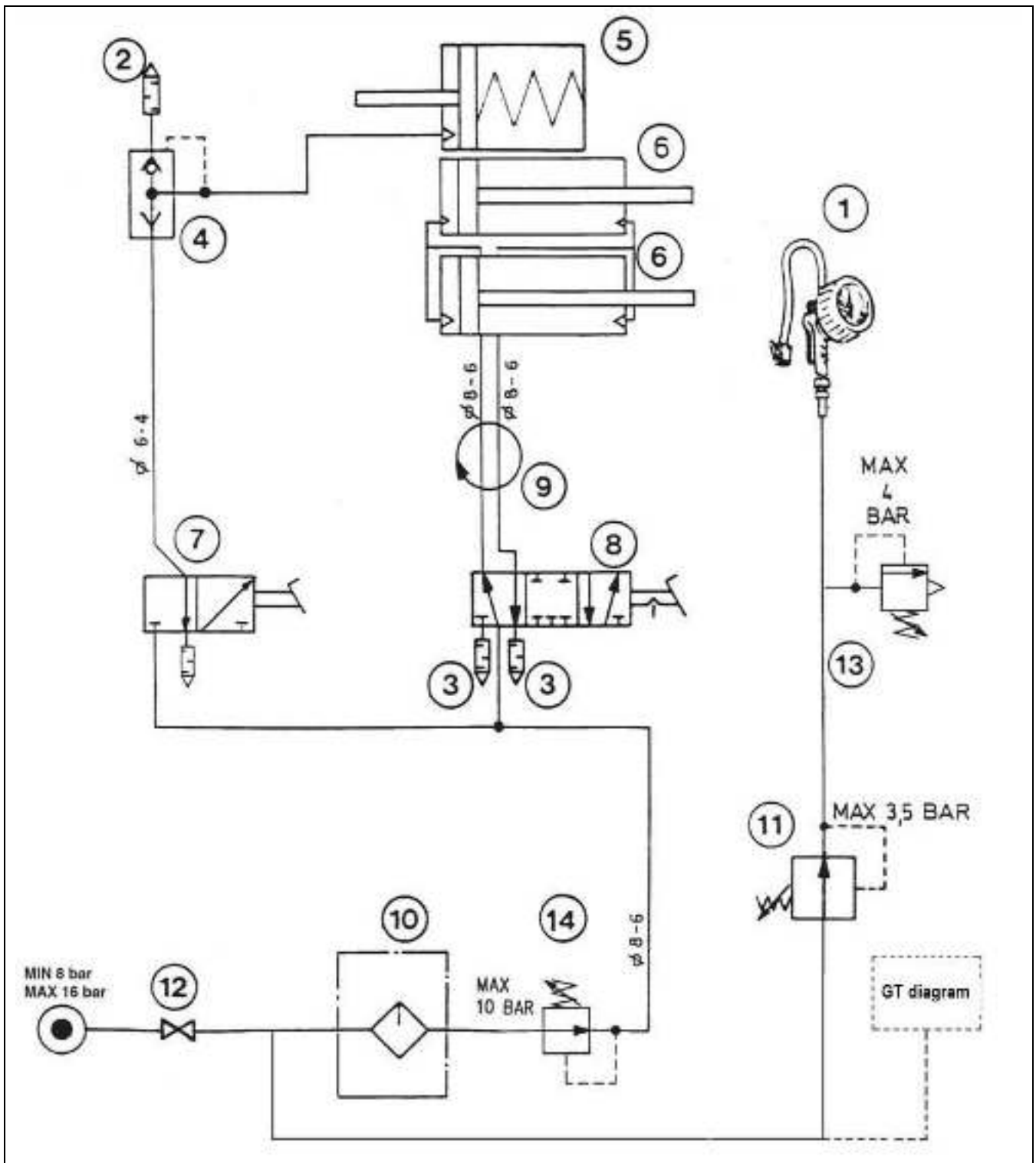

1	Inflating gauge	8	Turntable valve
2	Silencer 1/4"	9	Rotation union
3	Silencer 1/8"	10	Lubricator
4	Quick relief valve	11	Pressure regulator
5	Bead breaker cylinder	12	Air intake cock
6	Turntable cylinder	13	Safety valve
7	Bead breaking valve	14	Pressure regulator

GT PNEUMATIC SYSTEM DIAGRAM

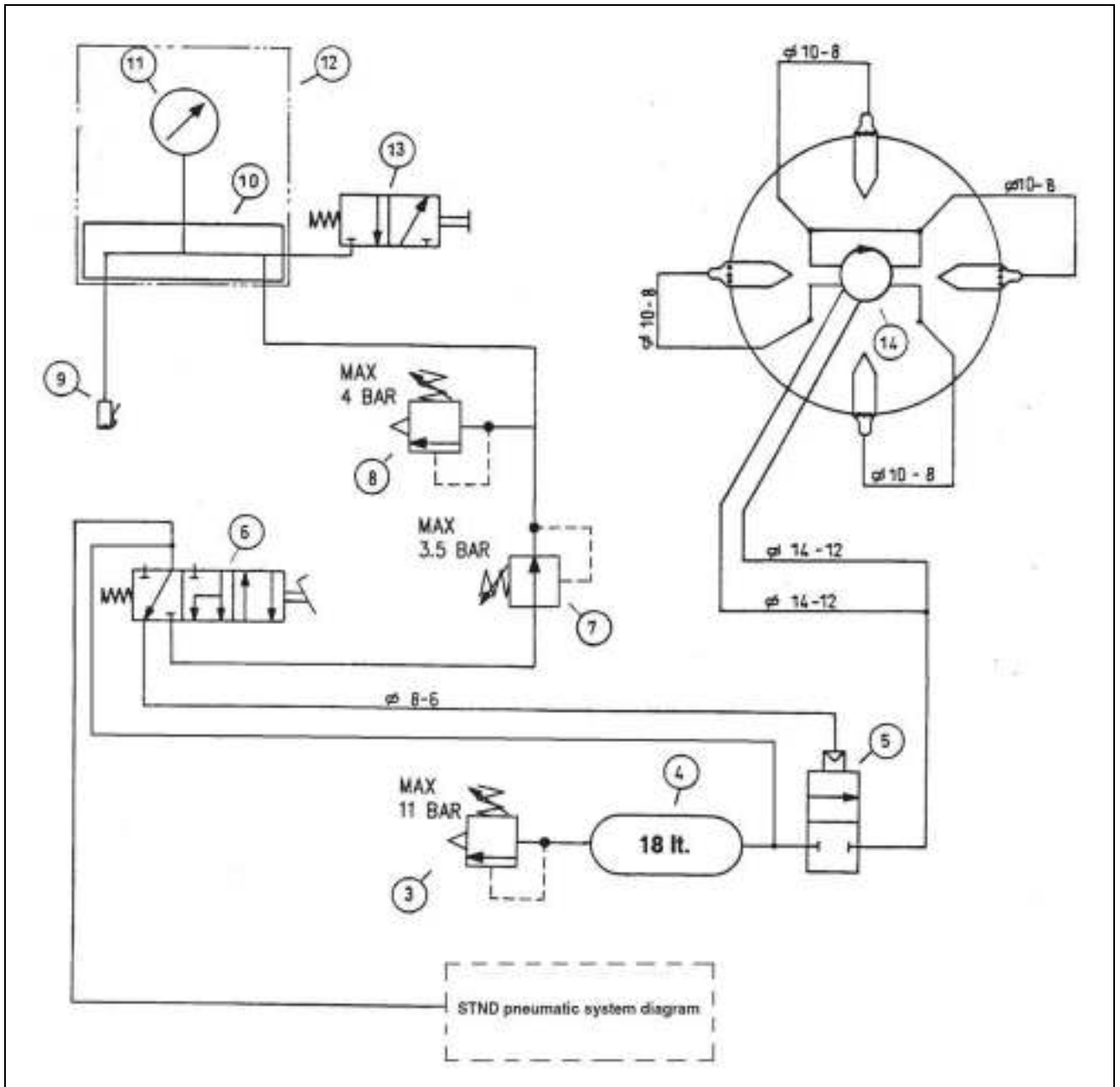

3	Safety Valve	10	Divider
4	Tank	11	Pressure gauge
5	Setting solenoid valve	12	Inflating unit
6	GT pedal valve	13	Deflating valve
8	Safety Valve	14	Rotation union
9	Inflating head		